



## MAIN FEATURES

- 10-bit Resolution
- 3 GSps Guaranteed Conversion Rate
- 6 GHz Analog Output Bandwidth
- 60 ps Full Scale Rise Time
- 4:1 or 2:1 integrated Parallel MUX (Selectable)
- Selectable Output Modes for Performance Optimization: Return to Zero, Non Return to Zero, Narrow Return to Zero, RF
- Low Latency Time: 3.5 Clock Cycles
- 1.4 Watt Power Dissipation in MUX 4:1 Mode
- Functions
  - Selectable MUX Ratio 4:1 (Full Speed), 2:1 (Half Speed)
  - Triple Majority Voting
  - User-friendly Functions:
    - Gain Adjustment
    - Input Data Check Bit (FPGA Timing Check)
    - Setup Time and Hold Time Violation Flags (STVF, HTVF)
    - Clock Phase Shift Select for Synchronization with DSP (PSS[2:0])
    - Output Clock Division Selection (Possibility to Change the Division Ratio of the DSP Clock)
    - Input Under Clocking Mode
    - Diode for Die junction Temperature Monitoring
- LVDS Differential Data input and DSP Clock Output
- Analog Output Swing: 1V<sub>pp</sub> Differential (100Ω Differential Impedance)
- External Reset for Synchronization of Multiple MuxDACs
- Power Supplies : 3.3 V (Digital), 3.3V & 5.0V (Analog)
- LGA255, CCGA255, Ci-CGA255 Package (21 × 21 mm Body Size, 1.27 mm Pitch)

## PERFORMANCES

Broadband: NPR at -14 dB Loading Factor

- 1st Nyquist (NRTZ): NPR = 46.0 dB 9.2 Bit Equivalent at Fs = 3 GSps
- 2nd Nyquist (NRTZ or RTZ): NPR = 40.0 dB 8.2 Bit Equivalent at Fs = 3 GSps
- 3rd Nyquist (RF): NPR = 38.0 dB 7.8 Bit Equivalent at Fs = 3 GSps

Single Tone: (see [Section 5. "Functional Description" on page 16](#))

- Performances Characterized for Fout from 100 MHz to 4500 MHz and from 2 GSps to 3.2 GSps.
- Performance Industrially Screened Over 3 Nyquist Zones at 3 GSps for Selected Fout.

Step Response

- Full Scale Rise /Fall Time < 60 ps

## APPLICATIONS

- Direct Digital Synthesis for Broadband Applications (L-S and Lower C Band)
- Automatic Test Equipment (ATE)
- Arbitrary Waveform Generators
- Satellite up-conversion Sub-systems
- Radar Waveform Signal Synthesis
- DOCSIS V3.0 Systems

Whilst Teledyne e2v Semiconductors SAS has taken care to ensure the accuracy of the information contained herein it accepts no responsibility for the consequences of any use thereof and also reserves the right to change the specification of goods without notice. Teledyne e2v Semiconductors SAS accepts no liability beyond the set out in its standard conditions of sale in respect of infringement of third party patents arising from the use of the devices in accordance with information contained herein.

Teledyne e2v Semiconductors SAS, avenue de Rochepleine 38120 Saint-Egrève, France

Holding Company: Teledyne e2v Semiconductors SAS

Telephone: +33 (0)4 76 58 30 00

Contact Teledyne e2v by e-mail: [hotline-bdc@teledyne-e2v.com](mailto:hotline-bdc@teledyne-e2v.com) or visit [www.teledyne-e2v.com](http://www.teledyne-e2v.com) for global sales and operations centres

# 1. BLOCK DIAGRAM

Figure 1-1. Simplified Block Diagram

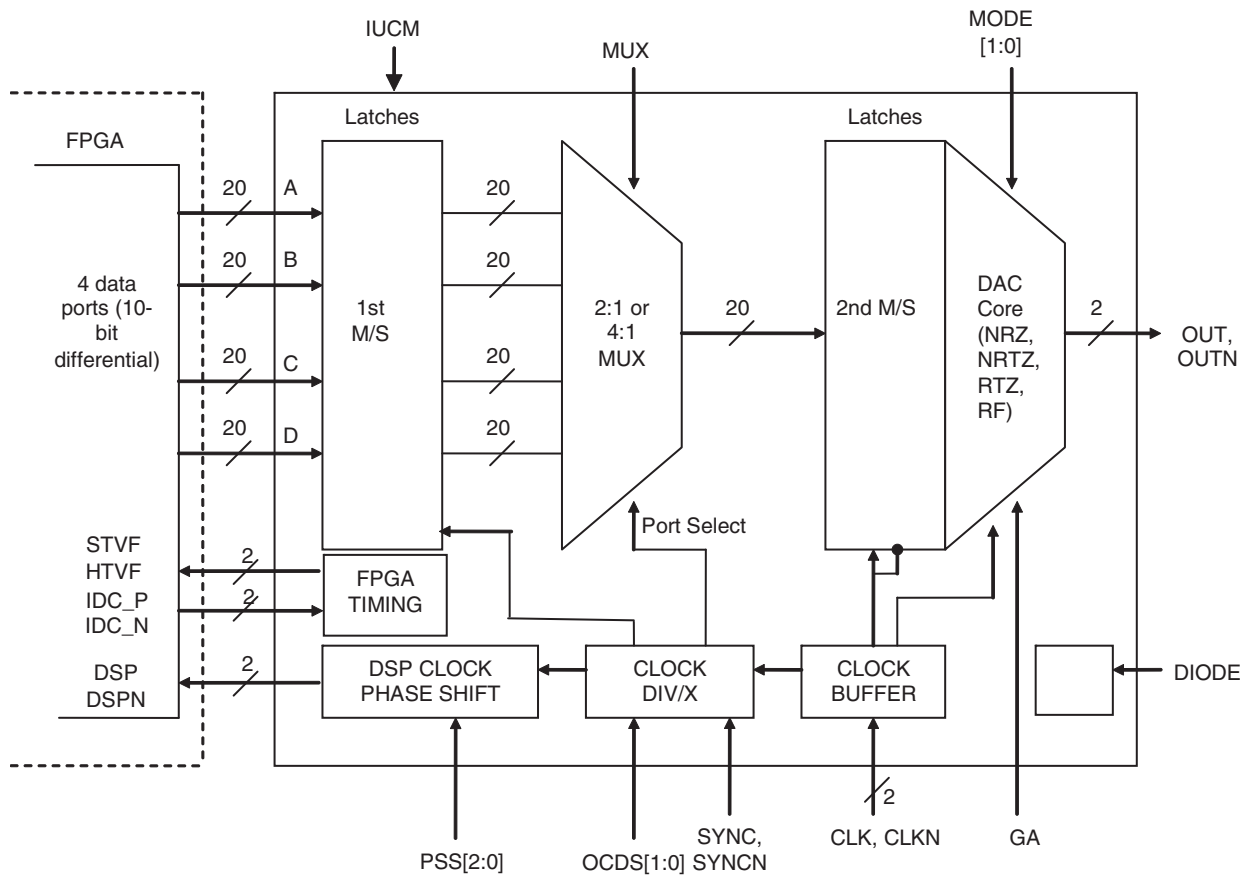

# 2. DESCRIPTION

The EV10DS130A/B is a 10-bit 3 GSps DAC with an integrated 4:1 or 2:1 multiplexer, allowing easy interface with standard LVDS FPGAs thanks to user friendly features as OCDS, PSS.

It embeds different output modes (RTZ, NRZ, narrow RTZ, RF) that allows performance optimizations depending on the working Nyquist zone.

The Noise Power Ratio (NPR) performance, over more than 900 MHz instantaneous bandwidth, and the high linearity (SFDR, IMD) over full 1<sup>st</sup> Nyquist zone at 3 GSps (NRZ feature), make this product well suited for high-end applications such as arbitrary waveform generators and broadband DDS systems.

### 3. ELECTRICAL CHARACTERISTICS

#### 3.1 Absolute Maximum Ratings

**Table 3-1. Absolute Maximum Ratings**

Parameter	Symbol	Value	Unit
Positive Analog supply voltage	$V_{CCA5}$	6.0	V
Positive Analog supply voltage	$V_{CCA3}$	4.0	V
Positive Digital supply voltage	$V_{CCD}$	4.0	V
Digital inputs (on each single-ended input) and IDC , SYNC, signal Port P = A, B, C, D $V_{IL}$ $V_{IH}$ Digital Input maximum Differential mode swing	[P0..P9], [PON.. P9N] IDC_P, IDC_N SYNC, SYNCN	GND-0.3 $V_{CCA3}$ 2.0	V V $V_{pp}$
Master clock input (on each single-ended input) $V_{IL}$ $V_{IH}$ Master Clock Maximum Differential mode swing	CLK, CLKN	1.5 3.5 2.5	V V $V_{pp}$
Control functions inputs $V_{IL}$ $V_{IH}$	MUX, MODE[0..1], PSS[0..2], OCDS[0..1]	-0.4V $V_{CCD} + 0.4$	V V
Gain Adjustment function	GA	-0.3V, $V_{CCA3} + 0.3$	V
Maximum Junction Temperature	$T_j$	170	°C
Storage Temperature	$T_{stg}$	-65 to 150	°C
Electrostatic discharge immunity ESD Classification	ESD HBM	1000 Class 1B	V

- Notes:
1. Absolute maximum ratings are limiting values (referenced to GND = 0V), to be applied individually, while other parameters are within specified operating conditions. Long exposure to maximum rating may affect device reliability.
  2. All integrated circuits have to be handled with appropriate care to avoid damages due to ESD. Damage caused by inappropriate handling or storage could range from performance degradation to complete failure.
  3. Maximum ratings enable active inputs with DAC powered off.
  4. Maximum ratings enable floating inputs with DAC powered on.
  5. DSP clock and STVF, HTVF output buffers must not be shorted to ground nor positive power supply.

### 3.2 Recommended Conditions of Use

**Table 3-2. Recommended Conditions of Use**

Parameter	Symbol	Comments	Recommended Value	Unit	Note
Positive analog supply voltage	$V_{CCA5}$		5.0	V	(2)(4)
Positive analog supply voltage	$V_{CCA3}$		3.3	V	(1)(2)(4)
Positive digital supply voltage	$V_{CCD}$		3.3	V	(2)(4)
Digital inputs (on each single-ended input) and IDC, SYNC, signal Port P = A, B, C, D $V_{IL}$ $V_{IH}$ Differential mode swing	[P0..P9], [P0N.. P9N] IDC_P, IDC_N SYNC, SYNCN		1.075 1.425 700	V V mV <sub>pp</sub>	(3)
Master clock input power level (Differential mode)	$P_{CLK}$		3	dBm	(3)
Control functions inputs	IUCM, MUX, OCDS, PSS, MODE, PSS	$V_{IL}$ $V_{IH}$	0 $V_{CCD}$	V V	
Gain Adjustment function	GA	Range	0 $V_{CCA3}$	V	
Operating Temperature Range	$T_c = T_{case}$ $T_j = T_{junction}$	Military "M" & space grade	$-55^{\circ}\text{C} < T_c, T_j < 125^{\circ}\text{C}$	$^{\circ}\text{C}$	

- Notes:
- For low temperature it is recommended to operate at maximum analog supplies ( $V_{CCA3}$ ) level.
  - The rise time of any power supplies ( $V_{CCD}$ ,  $V_{CCA5}$ ,  $V_{CCA3}$ ) shall be <10ms.  
For EV10DS130A, in order to obtain the guaranteed performances and functionality, the following rules shall be followed when powering the devices (See [Section 7.9 "Power Up Sequencing" on page 42](#))  
For EV10DS130B, no specific power up sequence nor power supplies relationships are required.
  - Analog output is in differential. Single-ended operation is not recommended. Guaranteed performance is only in differential configuration.
  - No power-down sequencing is required.

### 3.3 Electrical Characteristics

Values in the tables below are based on our conditions of measurement and valid over temperature range respectively for M, and Space quality level and for typical power supplies ( $V_{CCA5} = 5.0V$ ,  $V_{CCA3} = 3.3V$ ,  $V_{CCD} = 3.3V$ ), typical swing, unless specified and in MUX4:1 mode.

**Table 3-3.** Electrical Characteristics

Parameter	Symbol	Min	Typ	Max	Unit	Note	Test Level <sup>(2)</sup>
RESOLUTION		10			bit		1,6
<b>POWER REQUIREMENTS</b>							
Power Supply voltage							
- Analog	$V_{CCA5}$	4.75	5	5.25	V	(7)(8)	1,6
- Analog	$V_{CCA3}$	3.15	3.3	3.45	V		
- Digital	$V_{CCD}$	3.15	3.3	3.45	V		
Power Supply current (4:1 MUX)							
- Analog	$I_{CCA5}$		84	92	mA		1,6
- Analog	$I_{CCA3}$		106	125	mA		
- Digital	$I_{CCD}$		187	213	mA		
Power Supply current (2:1 MUX)							
- Analog	$I_{CCA5}$		84	92	mA		1,6
- Analog	$I_{CCA3}$		106	125	mA		
- Digital	$I_{CCD}$		160	185	mA		
Power dissipation (4:1 MUX)	$P_D$		1.4	1.6	W		1,6
Power dissipation (2:1 DMUX)	$P_D$		1.3	1.5	W		1,6
<b>DIGITAL DATA INPUTS, SYNC and IDC INPUTS</b>							
Logic compatibility		LVDS					
Digital input voltages:							
- Differential input voltage	$V_{ID}$	100	350	500	mV <sub>p</sub>		1,6
- Common mode	$V_{ICM}$		1.25		V		4
Input capacitance from each single input to ground				2	pF		5
Differential Input resistance		80	100	120	$\Omega$		1,6
<b>CLOCK INPUTS</b>							
Input voltages (Differential operation swing)		0.56	1	2.24	V <sub>pp</sub>		4
Power level (Differential operation)		-4	1	8	dBm		4
Common mode		2.4	2.5	2.6	V		4
Input capacitance from each single input to ground (at die level)			2		pF		5
Differential Input resistance		80	100	120	$\Omega$		1,6

**Table 3-3. Electrical Characteristics (Continued)**

Parameter	Symbol	Min	Typ	Max	Unit	Note	Test Level <sup>(2)</sup>
<b>DSP CLOCK OUTPUT</b>							
Logic compatibility		LVDS					
Digital output voltages:							
- Differential output voltage	$V_{OD}$	240	350	450	mV <sub>p</sub>		1,6
- Common mode	$V_{OCM}$		1.30		V		4
<b>ANALOG OUTPUT</b>							
Full-scale Differential output voltage (100Ω differentially terminated)		0.92	1	1.08	V <sub>pp</sub>		1,6
Full-scale output power (differential output)		0.25	1	1.64	dBm		1,6
Single-ended mid-scale output voltage (50Ω terminated)			$V_{CCA5} - 0.43$		V	(4)	
Output capacitance			1.5		pF		5
Output internal differential resistance		90	100	110	Ω		1, 6
Output VSWR (using e2v evaluation board)							
1.5 GHz			1.17				4
3 GHz			1.54				
4.5 GHz			1.64				
Output bandwidth			6		GHz		4
<b>FUNCTIONS</b>							
Digital functions: MODE, OCDS, PSS, MUX							
- Logic 0	$V_{IL}$		0	0.8	V		
- Logic 1	$V_{IH}$	1.6	$V_{CCD}$		V		
- Input Current	$I_{IN}$			150	μA	(6)	
Gain Adjustment function	GA		0				1,6
			$V_{CCA3}$				
Digital output function (HTVF, STVF)							
- Logic 0	$V_{OL}$	-	-	0.8	V	(5)	
- Logic 1	$V_{OH}$	2.1	-		V		1,6
- Output Current	$I_O$			80	μA	(6)	
<b>DC ACCURACY</b>							
Differential Non-Linearity	DNL+			0.90	LSB		1,6
Differential Non-Linearity	DNL-	-0.90			LSB		1,6
Integral Non-Linearity	INL+			1.5	LSB		1,6
Integral Non-Linearity	INL-	-1.5			LSB		1,6
DC gain:							
- Initial gain error		-8	0	+8	%		1,6
- DC gain adjustment			±11		%	(3)	4
- DC gain sensitivity to power supplies				+6	%		1,6
- DC gain drift over temperature			±2		%		4

Notes: 1. For use in higher Nyquist zone, it is recommended to use higher power clock within the limit.

2. See [Section 3.6 on page 14](#) for explanation of test levels.
3. Initial gain error corresponds to the deviation of the DC gain center value from unity gain. The DC gain adjustment (GA function) ensures that the initial gain deviation can be cancelled.  
The DC gain sensitivity to power supplies is given according the rule:  
 $\text{GainSensVsSupply} = |\text{Gain@VccMin} - \text{Gain@VccMax}| / \text{Gain@Vccnom}$
4. Single-ended operation is not recommended, this line is given for better understanding of what is output by the DAC.
5. In order to modify the  $V_{OL}/V_{OH}$  value, potential divider could be used.
6. Sink or source.
7. Only for EV10DS130A dependency between power supplies:  
Within the applicable power supplies range, the following relationship shall always be satisfied  $V_{CCA3} \geq V_{CCD}$ , taking into account AGND and DGND planes are merged and power supplies accuracy.
8. Please refer [Section 7.9 "Power Up Sequencing" on page 42](#).

### 3.4 AC Electrical Characteristics

Values in the tables below are based on our conditions of measurement and valid over temperature range respectively for M, and Space quality level and for typical power supplies ( $V_{CCA5} = 5.0V$ ,  $V_{CCA3} = 3.3V$ ,  $V_{CCD} = 3.3V$ ), typical swing, unless specified and in MUX4:1 mode.

**Table 3-4.** AC Electrical Characteristics NRZ Mode (First Nyquist Zone)

Parameter	Symbol	Min	Typ	Max	Unit	Note	Test level <sup>(1)</sup>
Single-tone Spurious Free Dynamic Range First Nyquist  Fs = 3 GSps @ Fout = 100 MHz 0 dBFS Fs = 3 GSps @ Fout = 100 MHz -3 dBFS	SFDR	55 56	66 67		dBc		1,6 1,6
Highest spur level First Nyquist  Fs = 3 GSps @ Fout = 100 MHz 0 dBFS Fs = 3 GSps @ Fout = 100 MHz -3 dBFS			-66 -69	-54 -57	dBm		1,6 1,6
SFDR sensitivity & high spur level variation over power supplies			±2		dB		4
Signal independent Spur (clock-related spur)  Fc/2 Fc/4			-82 -85		dBm dBm		4 4
Noise Power Ratio -14 dBFS peak to rms loading factor Fs = 3 GSps 20 MHz to 900 MHz broadband pattern, 25 MHz notch centered on 450 MHz	NPR	43	45		dB	(2)	1,6

**Table 3-4.** AC Electrical Characteristics NRZ Mode (First Nyquist Zone) (Continued)

Parameter	Symbol	Min	Typ	Max	Unit	Note	Test level <sup>(1)</sup>
Equivalent ENOB Computed from NPR figure at 3 GSps	ENOB	8.6	9.0		Bit	(2)	1,6
Signal to Noise Ratio Computed from NPR figure at 3 GSps	SNR	54	56		dB	(2)	1,6
DAC self noise density at code 0 or 1023				-150	dBm/Hz		1,6

Notes: 1. See [Section 3.6 on page 14](#) for explanation of test levels.

2. Figures in tables are derived from industrial screening; for practical reasons (necessity to cover also 2nd and 3rd Nyquist Zones) the balun used for industrial test is not optimum for first Nyquist performances, and results when Fout or folded low order harmonics are between DC to 400 MHz are very pessimistic.

**Table 3-5.** AC Electrical Characteristics NRTZ Mode (First & Second Nyquist Zone)

Parameter	Symbol	Min	Typ	Max	Unit	Note	Test level <sup>(1)</sup>
Single-tone Spurious Free Dynamic Range MUX4:1 Fs = 3 GSps @ Fout = 700 MHz 0 dBFS Fs = 3 GSps @ Fout = 1800 MHz 0 dBFS	SFDR	51	60		dBc		1,6
Fs = 3 GSps @ Fout = 700 MHz -3 dBFS		50	59			1,6	
MUX2:1 Fs = 1.5 GSps @ Fout = 700 MHz 0 dBFS		55	61			1,6	
Highest spur level MUX4:1 Fs = 3 GSps @ Fout = 700 MHz 0 dBFS Fs = 3 GSps @ Fout = 1800 MHz 0 dBFS					dBm		1,6
Fs = 3 GSps @ Fout = 700 MHz -3 dBFS			-64	-55		1,6	
MUX2:1 Fs = 1.5 GSps @ Fout = 700 MHz 0 dBFS			-63	-55		1,6	
SFDR sensitivity & high spur level variation over power supplies			±2		dB		4
Signal independent Spur (clock-related spur) Fc					dBm		4
Fc/2					dBm		4
Fc/4					dBm		4
DAC self noise density at code 0 or 1023				-138	dBm/Hz		1,6



**Table 3-5.** AC Electrical Characteristics NRTZ Mode (First & Second Nyquist Zone) (Continued)

Parameter	Symbol	Min	Typ	Max	Unit	Note	Test level <sup>(1)</sup>
Noise Power Ratio –14 dBFS peak to rms loading factor Fs = 3 GSps 20 MHz to 900 MHz broadband pattern, 25 MHz notch centered on 450 MHz	NPR	44	46		dB	(2)	1,6
Equivalent ENOB Computed from NPR figure at 3 GSps	ENOB	8.8	9.2		Bit	(2)	1,6
Signal to Noise Ratio Computed from NPR figure at 3 GSps	SNR	55	57		dB	(2)	1,6

Notes: 1. See [Section 3.6 on page 14](#) for explanation of test levels.

2. Figures in tables are derived from industrial screening; for practical reasons (necessity to cover also 2nd and 3rd Nyquist Zones) the balun used for industrial test is not optimum for first Nyquist performances, and results when Fout or folded low order harmonics are between DC to 400 MHz are very pessimistic.

**Table 3-6.** AC Electrical Characteristics RTZ Mode (Second Nyquist Zone)

Parameter	Symbol	Min	Typ	Max	Unit	Note	Test level <sup>(1)</sup>
Single-tone Spurious Free Dynamic Range MUX4:1 Fs = 3 GSps @ Fout = 1600 MHz 0 dBFS Fs = 3 GSps @ Fout = 2900 MHz 0 dBFS	SFDR	48	58 55		dBc		4 1,6
Highest spur level MUX4:1 Fs = 3 GSps @ Fout = 1600 MHz 0 dBFS Fs = 3 GSps @ Fout = 2900 MHz 0 dBFS			–66 –64	–56	dBm		4 1,6
SFDR sensitivity & high spur level variation over power supplies			±2		dB		4
Signal independent Spur (clock-related spur)							
Fc			–25		dBm		4
Fc/2			–80		dBm		4
Fc/4			–80		dBm		4
DAC self noise density at code 0 or 1023				–139	dBm/Hz		1,6

**Table 3-6.** AC Electrical Characteristics RTZ Mode (Second Nyquist Zone) (Continued)

Parameter	Symbol	Min	Typ	Max	Unit	Note	Test level <sup>(1)</sup>
Noise Power Ratio –14 dBFS peak to rms loading factor Fs = 3 GSps 1520 MHz to 2200 MHz broadband pattern, 25 MHz notch centered on 1850 MHz	NPR	37	40		dB		1,6
Equivalent ENOB Computed from NPR figure at 3 GSps	ENOB	7.6	8.2		Bit		1,6
Signal to Noise Ratio Computed from NPR figure at 3 GSps	SNR	48	51		dB		1,6

Notes: 1. See [Section 3.6 on page 14](#) for explanation of test levels.

**Table 3-7.** AC Electrical Characteristics RF Mode (Second and Third Nyquist Zones)<sup>(2)</sup>

Parameter	Symbol	Min	Typ	Max	Unit	Note	Test level <sup>(1)</sup>
Single-tone Spurious Free Dynamic Range 2 <sup>nd</sup> Nyquist Fs = 3 GSps @ Fout = 1600 MHz 0 dBFS	SFDR	42	50		dBc		1,6
3 <sup>rd</sup> Nyquist Fs = 3 GSps @ Fout = 3800 MHz 0 dBFS		43	50			1,6	
Fs = 3 GSps @ Fout = 4400 MHz 0 dBFS		43	50			1,6	
Highest spur level 2 <sup>nd</sup> Nyquist Fs = 3 GSps @ Fout = 1600 MHz 0 dBFS			–58	–49	dBm		1,6
3 <sup>rd</sup> Nyquist Fs = 3 GSps @ Fout = 3800 MHz 0 dBFS			–60	–51		1,6	
Fs = 3 GSps @ Fout = 4400 MHz 0 dBFS			–60	–54		1,6	
SFDR sensitivity & high spur level variation over power supplies			±2		dB		4
Signal independent Spur (clock-related spur)							
Fc			–28		dBm		4
Fc/2			–80		dBm		4
Fc/4			–80		dBm		4
DAC self noise density at code 0 or 1023				–138	dBm/Hz		1,6

**Table 3-7.** AC Electrical Characteristics RF Mode (Second and Third Nyquist Zones)<sup>(2)</sup> (Continued)

Parameter	Symbol	Min	Typ	Max	Unit	Note	Test level <sup>(1)</sup>
Noise Power Ratio (2 <sup>nd</sup> Nyquist) –14 dBFS peak to rms loading factor Fs = 3 GSps 1520 MHz to 2200 MHz broadband pattern, 25 MHz notch centered on 1850 MHz	NPR	35	38		dB		1,6
Equivalent ENOB Computed from NPR figure at 3 GSps	ENOB	7.3	7.8		Bit		1,6
Signal to Noise Ratio Computed from NPR figure at 3 GSps	SNR	46	49		dB		1,6
Noise Power Ratio –14 dBFS peak to rms loading factor Fs = 3 GSps 2200 MHz to 2880 MHz broadband pattern, 25 MHz notch centered on 2550 MHz	NPR	35	38		dB		1,6
Equivalent ENOB Computed from NPR figure at 3 GSps	ENOB	7.3	7.8		Bit		1,6
Signal to Noise Ratio Computed from NPR figure at 3 GSps	SNR	46	49		dB		1,6
Noise Power Ratio –14 dBFS peak to rms loading factor Fs = 3 GSps 3050 MHz to 3700 MHz broadband pattern, 25 MHz notch centered on 3375 MHz	NPR	35	38		dB	(2)	1,6
Equivalent ENOB Computed from NPR figure at 3 GSps	ENOB	7.3	7.8		Bit	(2)	1,6
Signal to Noise Ratio Computed from NPR figure at 3 GSps	SNR	46	49		dB	(2)	1,6

Notes: 1. See [Section 3.6 on page 14](#) for explanation of test levels.

2. Figures in tables are derived from industrial screening without any correction to take in account the balun effect, but for practical reasons (necessity to cover also 2nd and 3rd Nyquist Zones) the balun used for industrial test is not optimum for first Nyquist performances, and results when Fout or folded low order hamonics are between DC to 400 MHz are very pessimistic.

### 3.5 Timing Characteristics and Switching Performances

**Table 3-8.** Timing Characteristics and Switching Performances

Parameter	Symbol	Min	Typ	Max	Unit	Note	Test level <sup>(1)</sup>
<b>SWITCHING PERFORMANCE AND CHARACTERISTICS</b>							
Operating clock frequency							
4:1 MUX mode		300		3000	MHz		4
2:1 MUX mode		300		1500			
<b>TIMING CHARACTERISTICS</b>							
Analog output rise/fall time	$T_{OR}$ $T_{OF}$		60		ps	(2)	4
Data Tsetup (Fc = 3 Gsps)		250			ps	(3)	4
Data Thold (Fc = 3 Gsps)		100			ps	(3)	4
Max Input data rate (Mux 4:1)		75		750	MSps		4
Max Input data rate (Mux 2:1)		150		750	MSps		4
Master clock input jitter				100	fs rms	(4)	5
DSP clock phase tuning steps			0.5		Clock period		5
Master clock to DSP, DSPN delay	TDSP		1.6		ns		4
SYNC forbidden area lower bound (Fc = 3 Gsps)	$T_1$		200		ps	(5)(6)	4
SYNC forbidden area upper bound (Fc = 3 Gsps)	$T_2$		180		ps	(5)(6)	4
SYNC to DSP, DSPN MUX 2:1 MUX4:1			880 1600		ps		4
Data Pipeline Delay MUX4:1 MUX2:1	TPD		3.5 3.5		Clock period		4
Data Output Delay	TOD		160		ps		4

- Notes:
1. See [Section 3.6 on page 14](#) for explanation of the test level.
  2. Analog output rise/fall time measured from 20% to 80% of a full scale jump, after probe de-embedding.
  3. Exclusive of period (pp) jitter on Data. Setup and hold time for DATA at input relative to DSP clock at output of the component, at PSS = 000; also applicable for IDC signal.
  4. Master clock input jitter defined over 5 GHz bandwidth.
  5.  $T_C$  represents the master clock period. See [Figure 3-3](#).
  6. For EV10DS130A, please refer to erratasheet 1125

**Figure 3-1.** Timing Diagram for 4:1 MUX Principle of Operation OCDS[00]

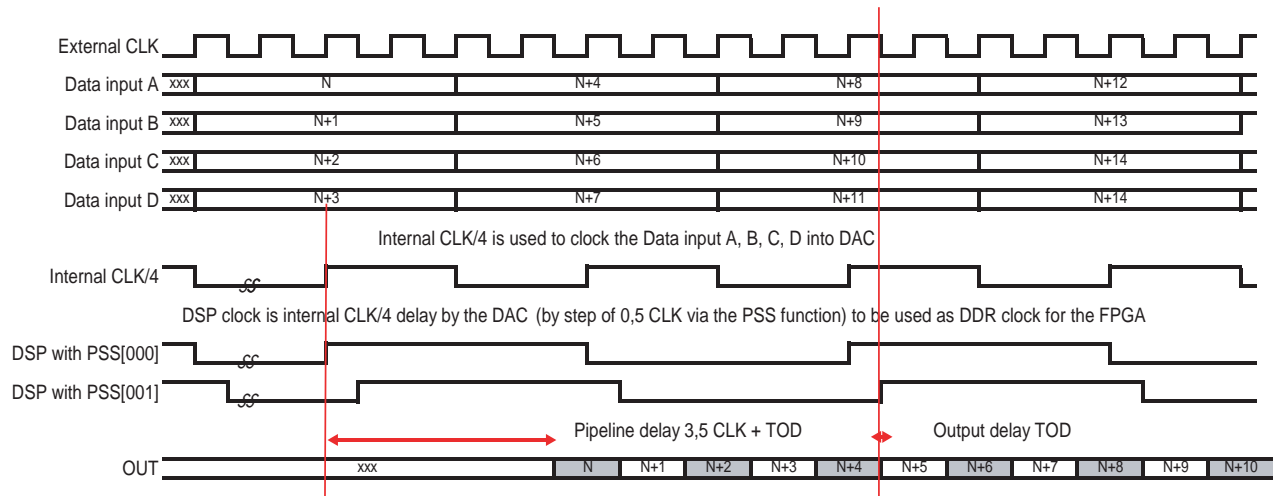

**Figure 3-2.** Timing Diagram for 2:1 MUX Principle of Operation OCDS[00]

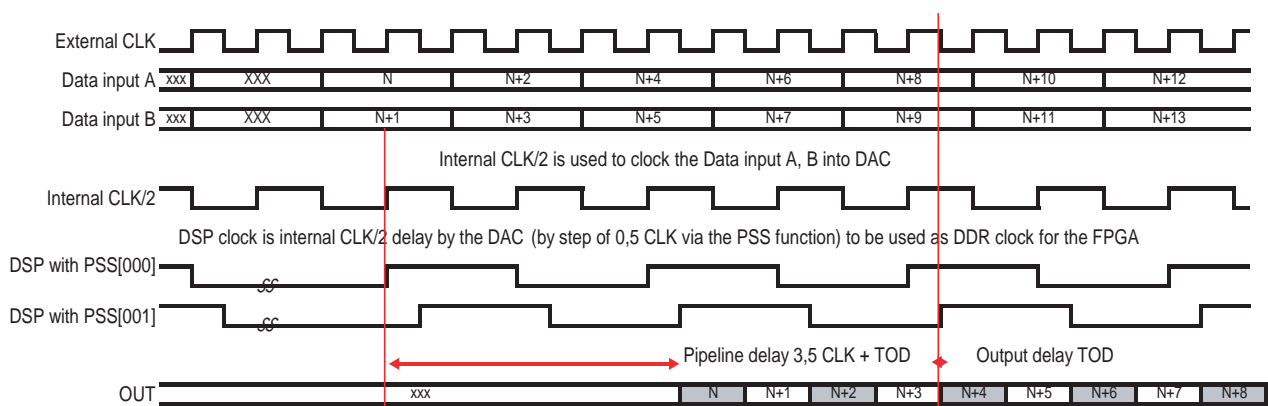

**Figure 3-3.** SYNC Timing Diagram

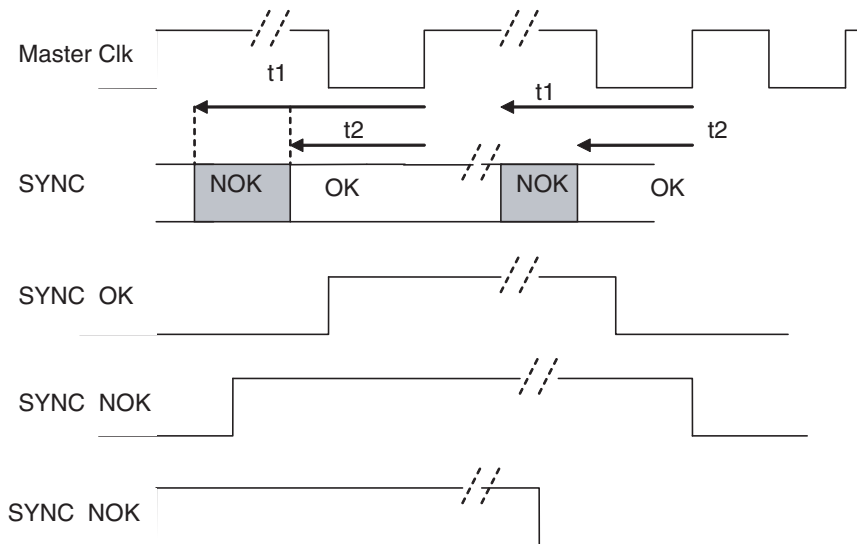

Please refer to [Section 5.9 "Synchronization Functions for Multi-DAC Operation"](#) on page 30.

### 3.6 Explanation of Test Levels

1	100% production tested at +25°C <sup>(1)</sup>
2	100% production tested at +25°C <sup>(1)</sup> , and sample tested at specified temperatures.
3	Sample tested only at specified temperatures
4	Parameter is guaranteed by design and/or characterization testing (thermal steady-state conditions at specified temperature).
5	Parameter value is only guaranteed by design
6	100% production tested over specified temperature range (for Space/Mil grade <sup>(2)</sup> )

Only MIN and MAX values are guaranteed.

- Notes: 1. Unless otherwise specified.  
 2. If applicable, please refer to "Ordering Information"

### 3.7 Digital Input Coding Table

**Table 3-9.** Coding Table

Digital output MSB.....LSB	Differential analog output
000000000	-500 mV
010000000	-250 mV
011000000	-125 mV
100000000	0 mV
101000000	+125 mV
110000000	+250 mV
111111111	+500 mV

## 4. DEFINITION OF TERMS

Abbreviation	Term	Definition
(Fs max)	<i>Maximum conversion Frequency</i>	Maximum conversion frequency
(Fs min)	<i>Minimum conversion frequency</i>	Minimum conversion Frequency
(SFDR)	<i>Spurious free dynamic range</i>	Ratio expressed in dB of the RMS signal amplitude, set at Full Scale, to the RMS value of the highest spectral component (peak spurious spectral component). The peak spurious component may or may not be a harmonic. It may be reported in dB (i.e., related to converter 0 dB Full Scale), or in dBc (i.e, related to input signal level).
(HSL)	<i>High Spur Level</i>	Power of highest spurious spectral component expressed in dBm.
(ENOB)	<i>Effective Number Of Bits</i>	ENOB is determined from NPR measurement with the formula: $ENOB = (NPR_{[dB]} +  LF_{[dB]}  - 3 - 1.76) / 6.02$ Where LF "Loading factor" is the ratio between the Gaussian noise standard deviation versus amplitude full scale.
(SNR)	<i>Signal to noise ratio</i>	SNR is determined from NPR measurement with the formula: $SNR_{[dB]} = NPR_{[dB]} +  LF_{[dB]}  - 3$ Where LF "Loading factor" is the ratio between the Gaussian noise standard deviation versus amplitude full scale.
(DNL)	<i>Differential non linearity</i>	The Differential Non Linearity for an given code i is the difference between the measured step size of code i and the ideal LSB step size. DNL (i) is expressed in LSBs. DNL is the maximum value of all DNL (i). DNL error specification of less than 1 LSB guarantees that there are no missing point and that the transfer function is monotonic.
(INL)	<i>Integral non linearity</i>	The Integral Non Linearity for a given code i is the difference between the measured voltage at which the transition occurs and the ideal value of this transition. INL (i) is expressed in LSBs, and is the maximum value of all  INL (i) .
(TPD/TOD)	<i>Output delay</i>	The analog output propagation delay measured between the rising edge of the differential CLK, CLKN clock input (zero crossing point) and the zero crossing point of a full-scale analog output voltage step. TPD corresponds to the pipeline delay plus an internal propagation delay (TOD) including package access propagation delay and internal (on-chip) delays such as clock input buffers and DAC conversion time.
(NPR)	<i>Noise Power Ratio</i>	The NPR is measured to characterize the DAC performance in response to broad bandwidth signals. When applying a notch-filtered broadband white-noise pattern at the input to the DAC under test, the Noise Power Ratio is defined as the ratio of the average noise measured on the shoulder of the notch and inside the notch on the same integration bandwidth.
(VSWR)	<i>Voltage Standing Wave Ratio</i>	The VSWR corresponds to the insertion loss linked to power reflection. For example a VSWR of 1:2 corresponds to a 20dB return loss (ie. 99% power transmitted and 1% reflected).
(IUCM)	<i>Input under clocking mode</i>	The IUCM principle is to apply a selectable division ratio between DAC section clock and the MUX section clock.
(PSS)	<i>Phase Shift Select</i>	The Phase Shift Select function allow to tune the phase of the DSPclock.
(OCDS)	<i>Output Clock Division Selectt</i>	It allows to divide the DSPclock frequency by the OCDS coded value factor
(NRZ)	<i>Non Return to Zero mode</i>	Non Return to Zero mode on analog output
(RF)	<i>Radio Frequency mode</i>	RF mode on analog output
(RTZ)	<i>Return to zero</i>	Return to zero mode
(NRTZ)	<i>Narrow return to zero</i>	Narrow return to zero mode

## 5. FUNCTIONAL DESCRIPTION

**Figure 5-1.** DAC Functional Diagram

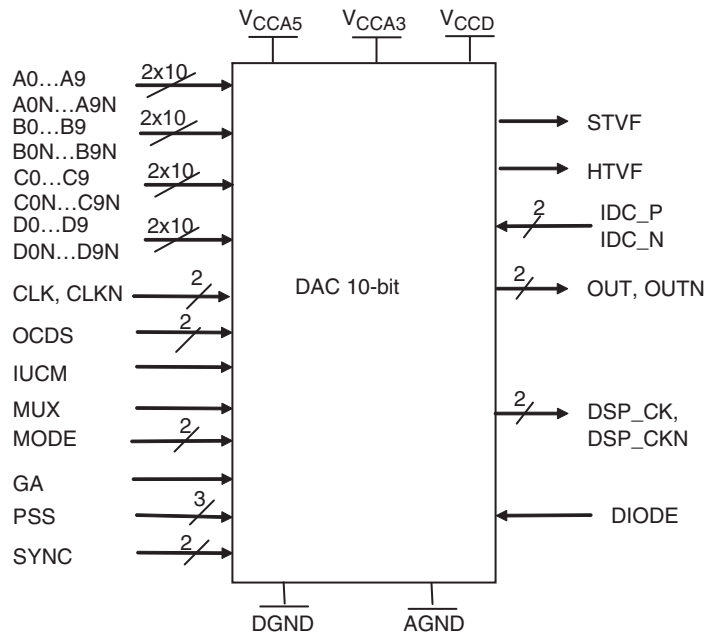

**Table 5-1.** Functions Description

Name	Function	Name	Function
V <sub>CCD</sub>	3.3V Digital Power Supply	CLK	In-phase Master clock
V <sub>CCA5</sub>	5.0V Analog Power Supply	CLKN	Inverted phase Master clock
V <sub>CCA3</sub>	3.3V Analog Power Supply	DSP_CK	In-phase Output clock
DGND	Digital Ground	DSP_CKN	Inverted phase Output clock
AGND	Analog ground (for analog supply reference)	PSS[0..2]	Phase shift select
A[9..0]	In-phase digital input Port A	GA	Gain Adjust
A[9..0]N	Inverted phase digital input Port A	MUX	MUX Selection
B[9..0]	In-phase digital input Port B	MODE[0..1]	DAC Mode: NRZ, RTZ, NRTZ, RF
B[9..0]N	Inverted phase digital input Port B	STVF	Setup time Violation flag
C[9..0]	In-phase digital input Port C	HTVF	Hold time Violation flag
C[9..0]N	Inverted phase digital input Port C	IDC_P, IDC_N	Input data check
D[9..0]	In-phase digital input Port D	OCDS[0..1]	Output Clock Division factor Selection (by 4 or 8)
D[9..0]N	Inverted phase digital input Port D	Diode	Diode for temperature monitoring
OUT	In-phase analog output	SYNC/SYCN	Synchronization signal (Active High)
OUTN	Inverted phase analog output	IUCM	Input underclocking mode



## 5.1 DSP Output Clock

The DSP output clock DSP, DSPN is an LVDS signal which is used to synchronize the FPGA generating the digital patterns with the DAC sampling clock.

The DSP clock frequency is a fraction of the sampling clock frequency. The division factor depends on OCDS settings. The DSP clock frequency is equal to (sampling frequency / [2N\*X]) where N is the MUX ratio and X is the output clock division factor, determined by OCDS[0..1] bits.

For example, in a 4:1 MUX ratio application with a sampling clock of 3 GHz and OCDS set to "00" (ie. Factor of 1), the input data rate is 750 MSps and the DSP clock frequency is 375 MHz.

This DSP clock is used in the FPGA to control the digital data sequencing. Its phase can be adjusted using the PSS[2:0] bits (refer to [Section 5.5 on page 25](#)) in order to ensure a proper synchronization between the data coming to the DAC and the sampling clock.

The HTVF and STVF bits should be used to check whether the timing between the FPGA and the DAC is correct. HTVF and STVF bits will indicate whether the DAC and FPGA are aligned or not. PSS bits should then be used to shift the DSP clock and thus the input data of the DAC, so that a correct timing is achieved between the FPGA and the DAC.

**Important note: Maximum supported sampling frequency when using DSP to clock digital data is 2.1 Gps on EV10DS130B. Please refer to application note AN1141 to use EV10DS130B at sampling frequency beyond 2.1 GHz.**

## 5.2 Multiplexer

Two multiplexer ratio are allowed:

- 4:1, which allows operation at full sampling rate (ie. 3 GHz)
- 2:1, which can only be used up to 1.5 GHz sampling rate, except in IUCM mode

Label	Value	Description
MUX	0	4:1 mode
	1	2:1 mode

In 2:1 MUX ratio, the unused data ports (ports C and D) can be left open.

## 5.3 MODE Function

Label	Value	Description	Default Setting (Not Connected)
MODE[1:0]	00	NRZ mode	11 RF mode
	01	Narrow RTZ (a.k.a. NRTZ) mode	
	10	RTZ Mode (50%)	
	11	RF mode	

The MODE function allows choosing between NRZ, NRTZ, RTZ and RF functions. NRZ and narrow RTZ should be chosen for use in 1<sup>st</sup> Nyquist zone while RTZ should be chosen for use in 2<sup>nd</sup> and RF for 3<sup>rd</sup> Nyquist zones.

Theory of operation: see following subsections for time domain waveform of the different modes.

Ideal equations describing max available Pout for frequency domain in the four modes are given hereafter, with X = normalised output frequency (that is Fout/Fclock, edges of Nyquist zones are then at X = 0, 1/2, 1, 3/2, 2, ...).

Due to limited bandwidth, an extra term must be added to take in account a first order low pass filter.

**NRZ mode:**

$$P_{out}(X) = 20 \cdot \log_{10} \cdot \left[ \frac{|k \cdot \text{sinc}(k \cdot \pi \cdot X)|}{0.893} \right]$$

where sinc(x) = sin(x)/x, and k = 1

**NRTZ mode:**

$$P_{out}(X) = 20 \cdot \log_{10} \cdot \left[ \frac{|k \cdot \text{sinc}(k \cdot \pi \cdot X)|}{0.893} \right] \quad k = \frac{T_{clk} - T_{\tau}}{T_{clk}}$$

where Tτ is width of reshaping pulse, Tτ is about 75ps.

**RTZ mode:**

$$P_{out}(X) = 20 \cdot \log_{10} \cdot \left[ \frac{|k \cdot \text{sinc}(k \cdot \pi \cdot X)|}{0.893} \right]$$

where k is the duty cycle of the clock presented at the DAC input, please note that due to phase mismatch in balun used to convert single ended clock to differential clock the first zero may move around the limit of the 4<sup>th</sup> and the 5<sup>th</sup> Nyquist zones. Ideally k = 1/2.

**RF mode:**

$$P_{out}(X) = 20 \cdot \log_{10} \cdot \left[ \frac{\left| k \cdot \text{sinc}\left(\frac{k \cdot \pi \cdot X}{2}\right) \cdot \sin\left(\frac{k \cdot \pi \cdot X}{2}\right) \right|}{0.893} \right]$$

where k is as per in NRTZ mode.

As a consequence:

- NRZ mode offers max power for 1<sup>st</sup> Nyquist operation
- RTZ mode offers slow roll off for 2<sup>nd</sup> Nyquist or 3<sup>rd</sup> Nyquist operation
- RF mode offers maximum power over 2<sup>nd</sup> and 3<sup>rd</sup> Nyquist operation
- NRTZ mode offers optimum power over full 1<sup>st</sup> and first half of 2<sup>nd</sup> Nyquist zones. This is the most relevant in term of performance for operation over 1<sup>st</sup> and beginning of 2<sup>nd</sup> Nyquist zone, depending on the sampling rate the zero of transmission moves in the 3<sup>rd</sup> Nyquist zone from begin to end when sampling rate increases.

Note in the two following figures: Pink line is ideal equation's result, and green line includes a first order 6 GHz cut-off low pass filter to take in account finite bandwidth effect due to die and package.

**Figure 5-2.** Max available Pout[dBm] at nominal gain vs Fout[GHz] in the four output modes at 3 GSps, over four Nyquist zones, computed for  $\tau = 75$  ps.

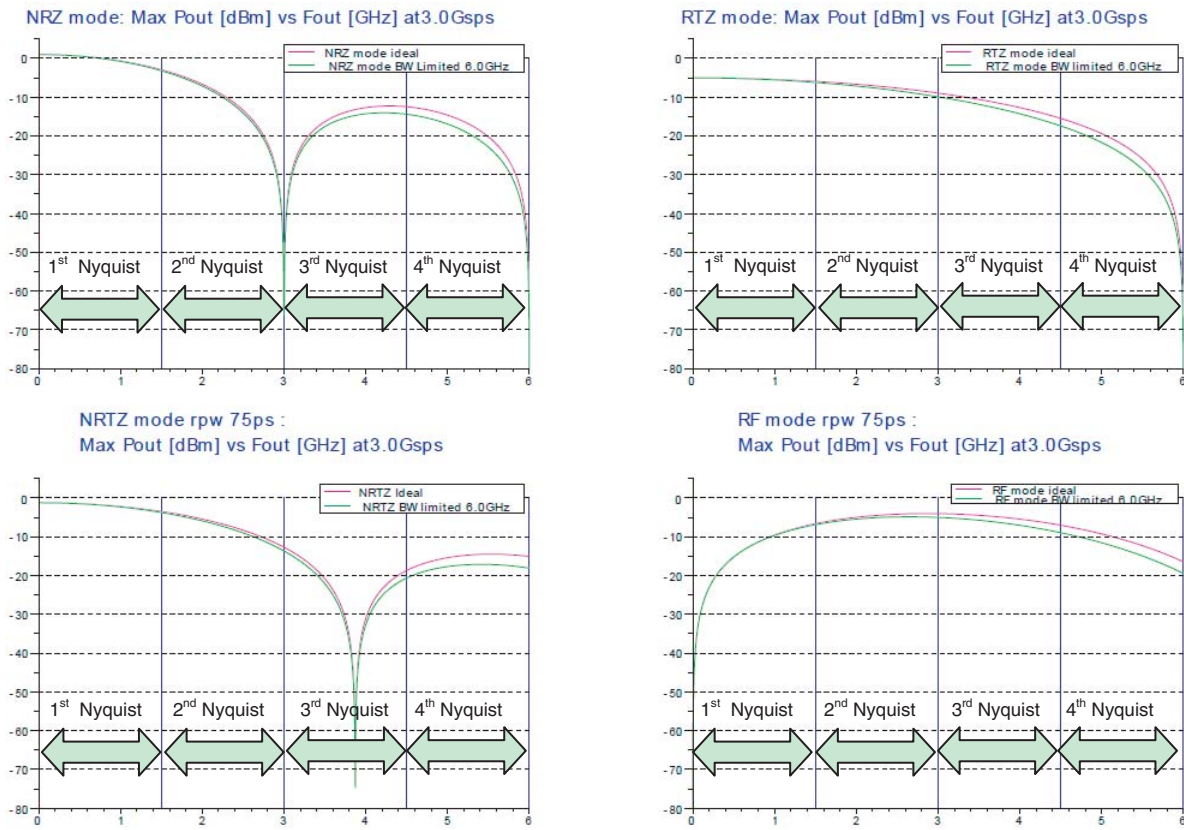

**Figure 5-3.** Max available Pout[dBm] at nominal gain vs Fout[GHz] in the four output modes at 2 GSps, over four Nyquist zones, computed for  $\tau = 75$  ps

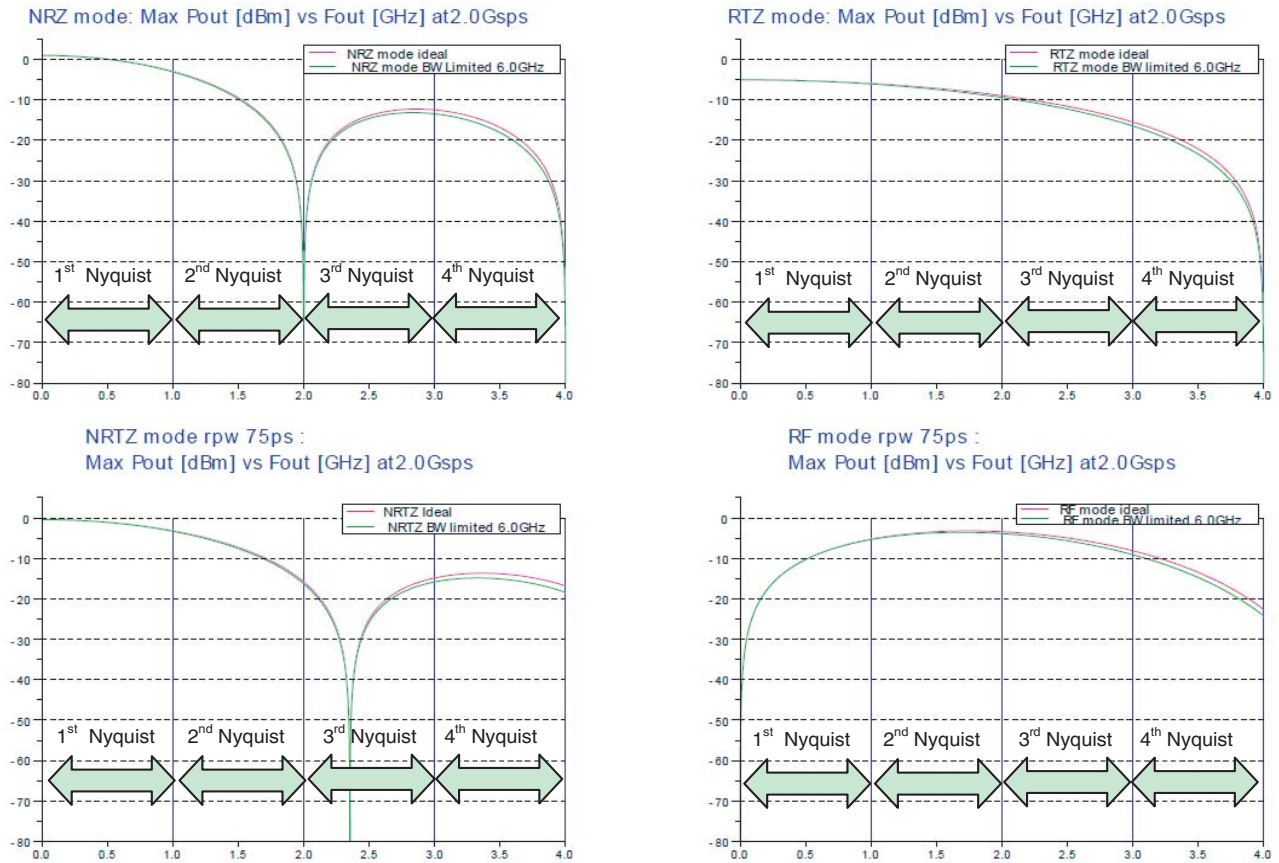

### 5.3.1 NRZ Output Mode

This mode does not allow for operation in the 2<sup>nd</sup> Nyquist zone because of the  $\text{Sin}(x)/x$  notch.

The advantage is that it gives good results at the beginning of the 1<sup>st</sup> Nyquist zone (less attenuation than in RTZ architecture), it removes the parasitic spur at the clock frequency (in differential).

**Figure 5-4.** NRZ Timing Diagram

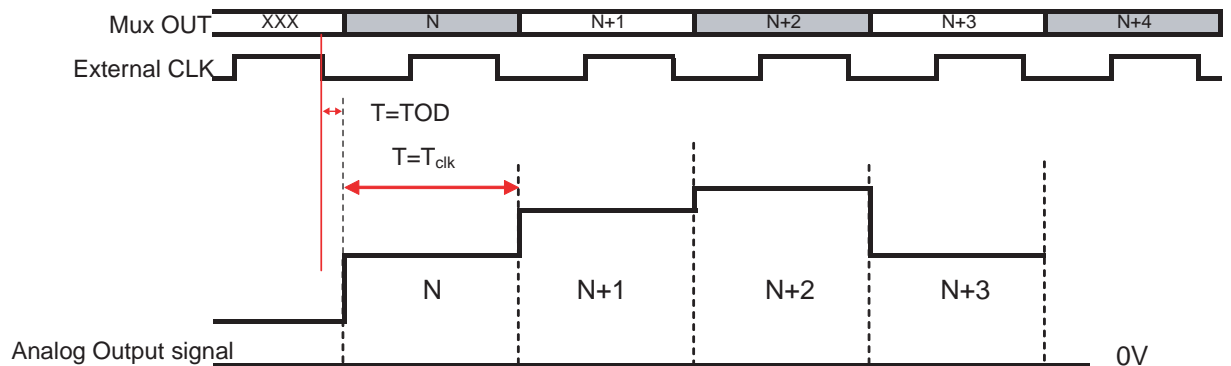

### 5.3.2 Narrow RTZ (NRTZ) Mode

This mode has the following advantages:

- Optimized power in 1<sup>st</sup> Nyquist zone
- Extended dynamic through elimination of noise on transition edges
- Improved spectral purity
- Trade off between NRZ and RTZ

**Figure 5-5.** Narrow RTZ Timing Diagram

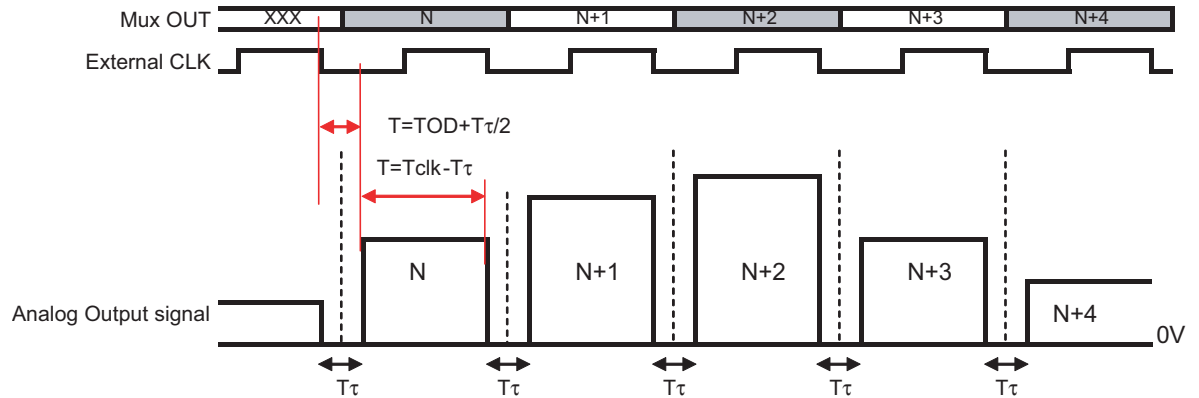

Note:  $T\tau$  is independent of  $F_{clock}$ .

### 5.3.3 RTZ Mode

The advantage of the RTZ mode is to enable the operation in the 2<sup>nd</sup> zone but the drawback is a highest attenuation of the signal in the first Nyquist zone.

Advantages:

- Extended roll off of sinc
- Extended dynamic through elimination of noise on transition edges

Weakness:

- By construction clock spur at  $F_s$ .

**Figure 5-6. RTZ Timing Diagram**

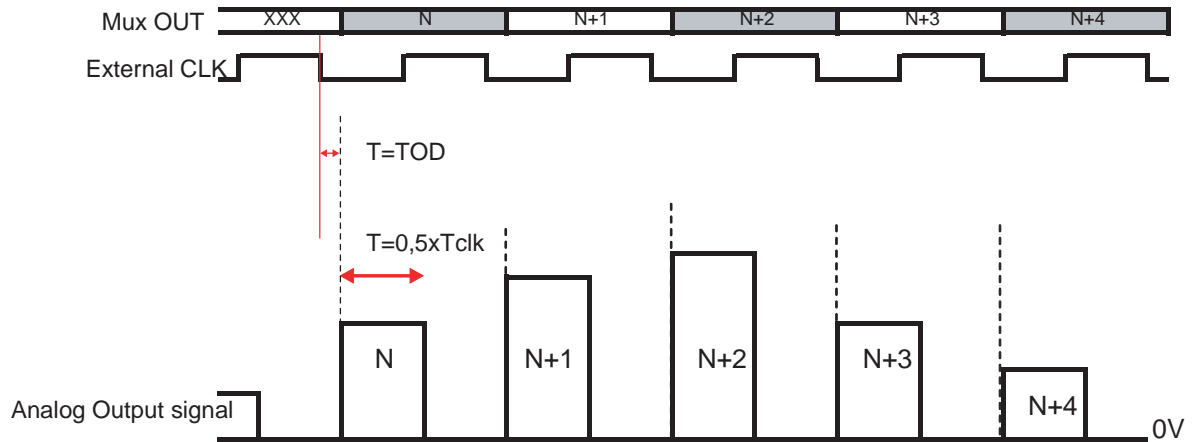

### 5.3.4 RF Mode

RF mode is optimal for operation at high output frequency, since the decay with frequency occurs at higher frequency than for RTZ. Unlike NRZ or RTZ modes, RF mode presents a notch at DC and  $2N \cdot F_s$ , and minimum attenuation for  $F_{out} = F_s$ .

Advantages:

- Optimized for 2<sup>nd</sup> and 3<sup>rd</sup> Nyquist operation
- Extended dynamic range through elimination of noise on transition edges.
- Clock spur pushed to  $2 \cdot F_s$

**Figure 5-7. RF Timing Diagram**

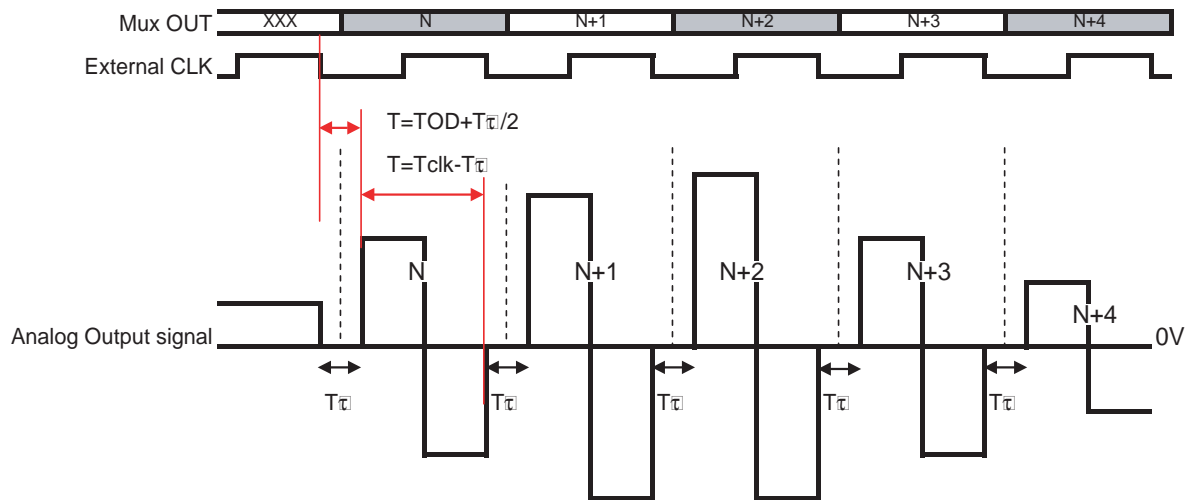

Note: The central transition is not hazardous but its elimination allows to push clock spur to  $2 \cdot F_s$ .  $T_{\tau}$  is dependant of  $F_{clock}$ .

#### 5.4 Input Under Clocking Mode (IUCM), Principle and Spectral Response

An Input Under Clocking Mode has been added to the DAC in order to allow the DAC input data rate to be at half the nominal rate with respect of the DAC sampling rate.

When the under clocking mode is activated, the DAC expects data at half the nominal rate: if the DAC works at  $F_s$  sampling rate, then in 4:1 MUX mode, the input data rate should be  $F_s/4$  and the DSP clock should be  $F_s/(2N \cdot OCDS)$ , with  $N = \text{MUX ratio}$  and  $OCDS = \text{OCDS Ratio}$ .

When the IUCM is active, the input data rate can be  $F_s/8$  and the DSP clock frequency is  $F_s/(2N \cdot OCDS \cdot 2)$ , with  $N = \text{MUX ratio}$  and  $OCDS = \text{OCDS Ratio}$ . This means that in input under clocking mode, the DAC is capable to treat data at half the nominal rate. In this case, the DSP clock is also half its nominal speed.

Label	Logic Value	Description
IUCM	0	Input Under Clocking Mode inactive
	1	Input Under Clocking Mode active

To disable this mode, the IUCM pin must be connected to GND.

To enable this mode, IUCM must be connected to  $V_{CCD}$  or left unconnected

The IUCM mode affects spectral response of the different modes.

The first effect is that Nyquist zone edges are not anymore at  $n \cdot F_{clock}/2$  but at  $n \cdot F_{clock}/4$  (direct consequence of the division by 2 of the data rate).

The second effect is the modification of the equations ruling the spectral responses in the different modes.

Ideal equations describing max available  $P_{out}$  for frequency domain in the four output modes when IUCM mode is activated are given hereafter, with  $X =$  normalised output frequency (that is  $F_{out}/F_{clock}$ , edges of Nyquist Zones are then at  $X = 0, 1/4, 1/2, 3/4, 1, \dots$ )

In fact due to limited bandwidth, an extra term must be added to take in account a first order low pass filter with a 6 GHz cut-off frequency.

**NRZ mode:**

$$P_{out}(X) = 20 \cdot \log_{10} \cdot \left[ \frac{k \cdot \text{sinc}(k \cdot \pi \cdot X) \cdot \cos(\pi \cdot X)}{0.893} \right]$$

where  $\text{sinc}(x) = \sin(x)/x$ , and  $k = 1$

**NRTZ mode:**

$$P_{out}(X) = 20 \cdot \log_{10} \cdot \left[ \frac{k \cdot \text{sinc}(k \cdot \pi \cdot X) \cdot \cos(\pi \cdot X)}{0.893} \right] \quad k = \frac{T_{clk} - T_{\tau}}{T_{clk}}$$

where  $T_{\tau}$  is width of reshaping pulse,  $T_{\tau}$  is about 75ps.

**RTZ mode:**

$$P_{out}(X) = 20 \cdot \log_{10} \cdot \left[ \frac{k \cdot \text{sinc}(k \cdot \pi \cdot X) \cdot \cos(\pi \cdot X)}{0.893} \right]$$

where k is the duty cycle of the clock presented at the DAC input, please note that due to phase mismatch in balun used to convert single ended clock to differential clock the first zero may move around the limit of the 4<sup>th</sup> and the 5<sup>th</sup> Nyquist zones. Ideally k = 1/2.

**RF mode:**

$$P_{out}(X) = 20 \cdot \log_{10} \cdot \left[ \frac{k \cdot \text{sinc}\left(\frac{k \cdot \pi \cdot X}{2}\right) \cdot \sin\left(\frac{k \cdot \pi \cdot X}{2}\right) \cdot \cos(\pi \cdot X)}{0.893} \right]$$

where k is as per in NRTZ mode.

**Figure 5-8.** Max available Pout[dBm] at nominal gain vs Fout[GHz] in the four output modes at 3 GSps, combined with IUCM, over four nyquist zones, computed for Tτ =75 ps.

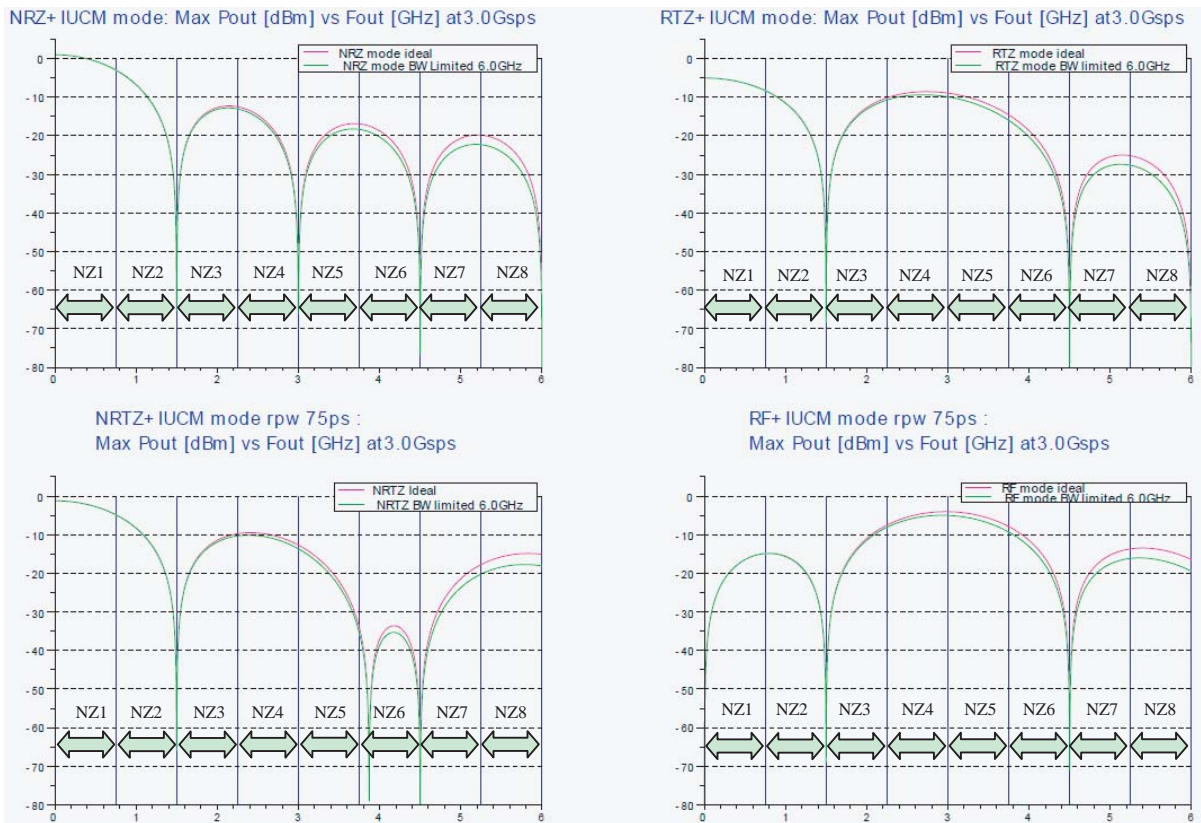



**Figure 5-9.** Max available Pout[dBm] at nominal gain vs Fout[GHz] in the four output modes at 2 GSps, combined with IUCM, over four nyquist zones, computed for  $T\tau = 75$  ps

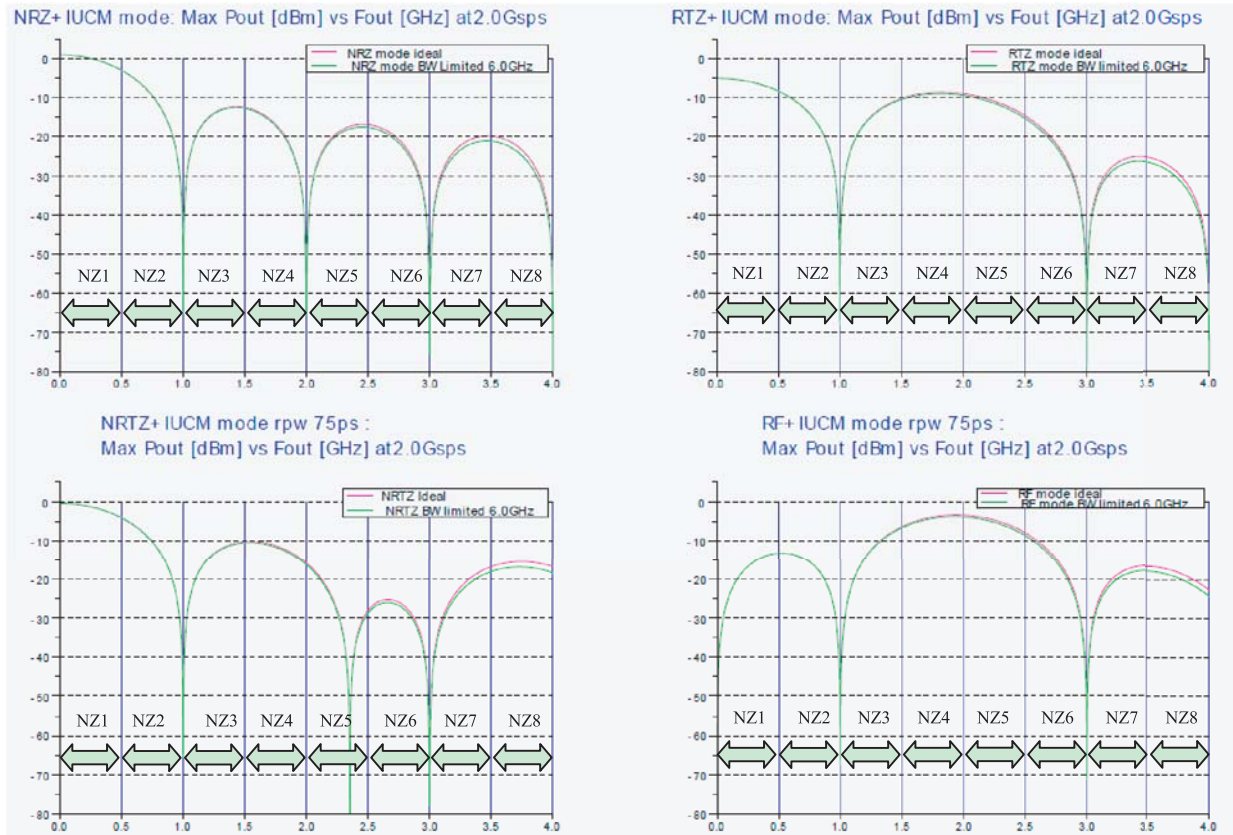

## 5.5 PSS (Phase Shift Select Function)

It is possible to adjust the timings between the sampling clock and the DSP output clock (which frequency is given by the following formula: Sampling clock /  $2NX$  where  $N$  is the MUX ratio,  $X$  the output clock division factor).

The DSP clock output phase can be tuned over a range of 3.5 input clock cycles (7 steps of half a clock cycle) in addition to the intrinsic propagation delay between the DSP clock (DSP, DSPN) and the sampling clock (CLK, CLKN).

Three bits are provided for the phase shift function: PSS[2:0].

By setting these 3 bits to 0 or 1, one can add a delay on the DSP clock in order to properly synchronize the input data of the DAC and the sampling clock (the DSP clock should be applied to the FPGA and should be used to clock the DAC digital input data).

**Table 5-2.** PSS Coding Table

Label	Value	Description
PSS[2:0]	000	No additional delay on DSP clock
	001	0.5 input clock cycle delay on DSP clock
	010	1 input clock cycle delay on DSP clock
	011	1.5 input clock cycle delay on DSP clock
	100	2 input clock cycles delay on DSP clock
	101	2.5 input clock cycles delay on DSP clock
	110	3 input clock cycles delay on DSP clock
	111	3.5 input clock cycles delay on DSP clock

In order to determine how much delay needs to be added on the DSP clock to ensure the synchronization between the input data and the sampling clock within the DAC, the HTVF and STVF bits should be monitored. Refer to [Section 5.7 on page 28](#).

Note: In MUX 4:1 mode the 8 settings are relevant, in MUX 2:1 only the four first settings are relevant since the four last ones will yield exactly the same results.

**Figure 5-10.** PSS Timing Diagram for 4:1 MUX, OCDS[00]

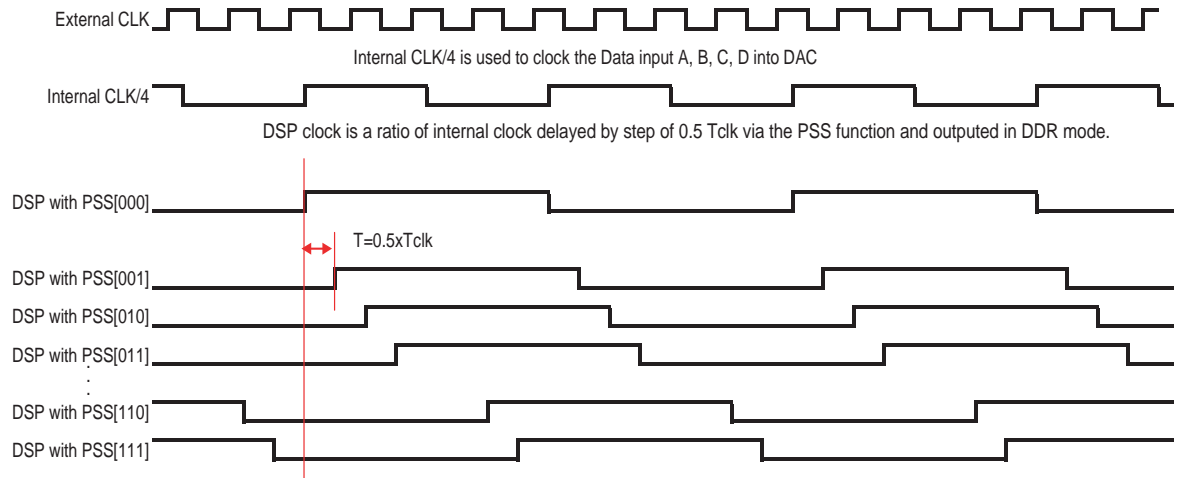

**Figure 5-11. PSS Timing Diagram for 2:1 MUX, OCDS[00]**

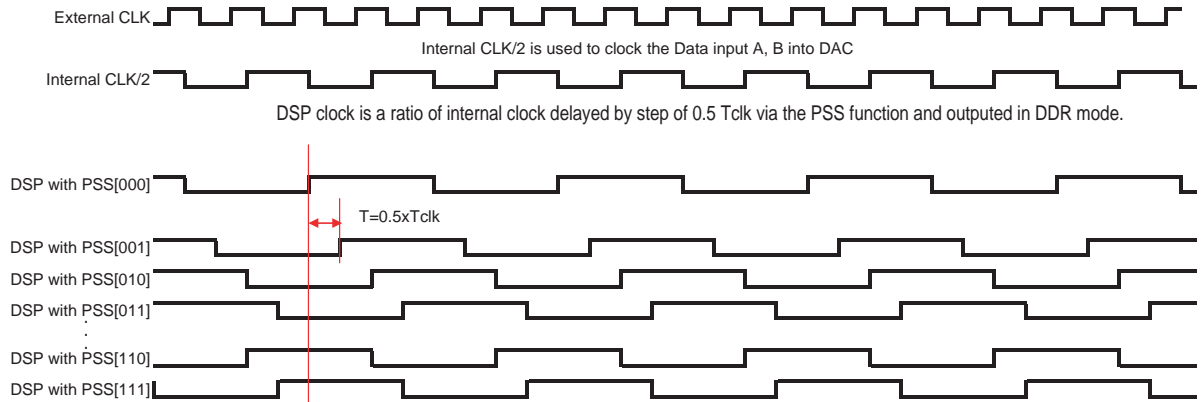

### 5.6 Output Clock Division Select Function

It is possible to change the DSP clock internal division factor from 1 to 2 and 4 with respect to the sampling clock/ $2N$  where  $N$  is the MUX ratio. This is possible via the OCDS "Output Clock Division Select" bits.

OCDS is used to obtain a synchronisation clock for the FPGA slow enough to allow the FPGA to operate with no further internal division of this clock, thus its internal phase is determined by the DSP clock phase. This is useful in a system with multiple DACs and multiple FPGAs to guarantee deterministic phase relationship between the FPGAs after a synchronisation of all the DACs.

**Table 5-3. OCDS[1:0] Coding Table**

Label	Value	Description
OCDS [1:0]	00	DSP clock frequency is equal to the sampling clock divided by $2N$
	01	DSP clock frequency is equal to the sampling clock divided by $2N \times 2$
	10	Not allowed
	11	Not allowed

**Figure 5-12. OCDS Timing Diagram for 4:1 MUX**

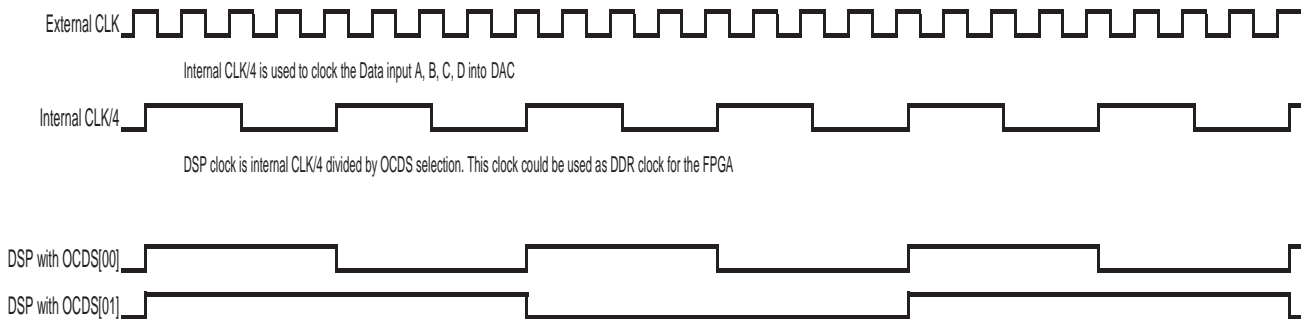

**Figure 5-13.** OCDS Timing Diagram for 2:1 MUX

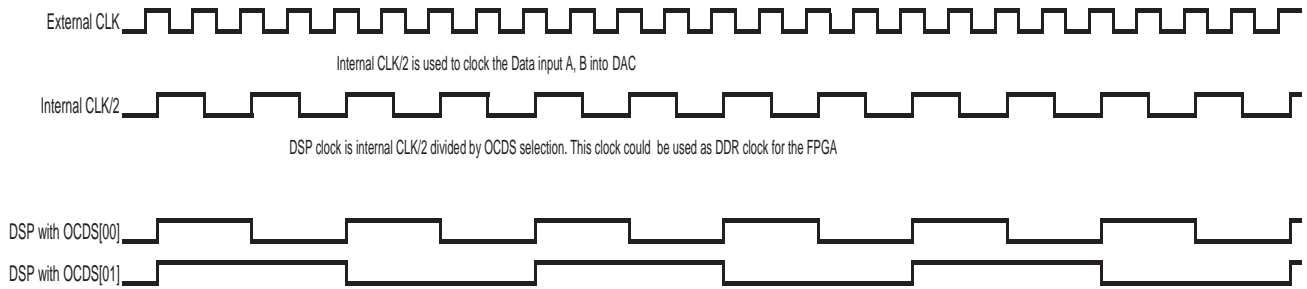

### 5.7 Synchronization FPGA-DAC: IDC\_P, IDC\_N, HTVF and STVF Functions

IDC\_P, IDC\_N: Input Data check function (LVDS signal).

HTVF: Hold Time Violation Flag. (CMOS3.3V signal)

STVF: Setup Time Violation Flag. (CMOS3.3V signal)

This signal is toggling at each cycle synchronously with other data bits. This signal should be considered as DAC input data that is toggling at each cycle.

This signal should be generated by the FPGA in order the DAC to check in real-time if the timings between the FPGA and the DAC are correct.

**Figure 5-14.** IDC Timing vs Data Input

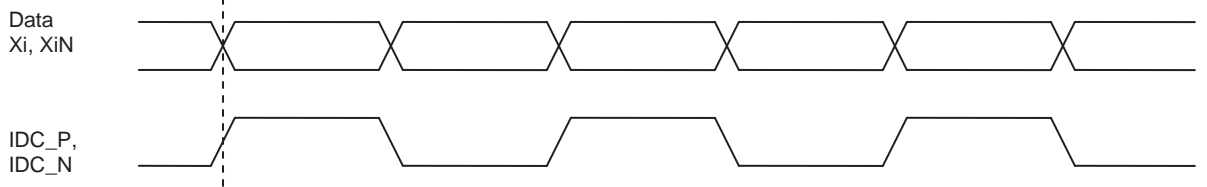

The information on the timings is then given by HTVF, STVF signals (flags).

**Table 5-4.** HTVF, STVF Coding Table

Label	Value	Description
HTVF	0	SYNCHRO OK
	1	Data Hold time violation detected
STVF	0	SYNCHRO OK
	1	Data Setup time violation detected

During Monitoring STVF indicates setup time of data violation (Low -> OK, High -> Violation), HTVF indicates hold time of data violation (Low -> OK, High -> Violation).

**Figure 5-15. FPGA to DAC Synoptic**

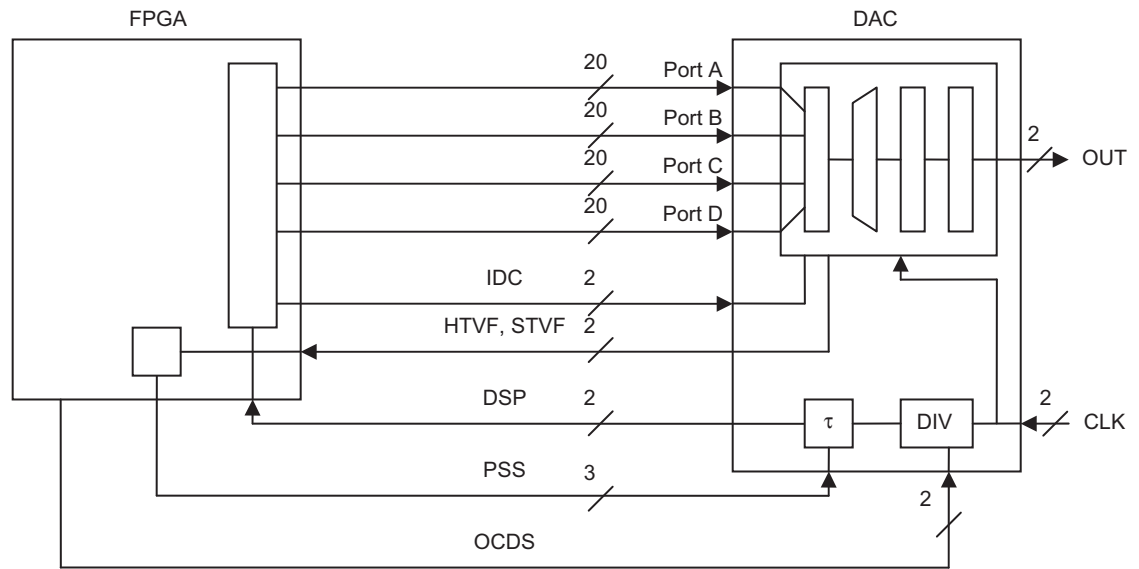

**Principle of Operation:**

The Input Data Check pair (IDC\_P, IDC\_N) will be sampled three times with half a master clock period shift (the second sample being synchronous with all the data sampling instant), these three samples will be compared, and depending on the results of the comparison a violation may be signalled.

- Violation of setup time -> STVF is high level
- Violation of hold time -> HTVF is high level

In case of violation of timing (setup or hold) the user has two solutions:

- Shift phase in the FPGA PLL (if this functionality is available in FPGA) for changing the internal timing of DATA and Data Check signal inside FPGA.
- Shift the DSP clock timing (Output clock of the DAC which can be used for FPGA synchronization – refer to [Section 5.5 on page 25](#)), in this case this shift also shift the internal timing of FPGA clock.

Note: When used, it should be routed as the data signals (same layout rules and same length). if not used, it should be driven to an LVDS low or high level.

For further details, refer to application note AN1087.

## 5.8 OCDS, IUCM, MUX Combinations Summary

**Table 5-5.** OCDS, IUCM, MUX, PSS Combinations Summary

MUX		IUCM		OCDS		PSS range	Data rate	Comments
0	4:1	1	ON	00	DSP clock division factor 16	0 to 7/(2Fs) by 1/(2Fs) steps	Fs/8	Refer to <a href="#">Section 5.6</a>
0		1		01	DSP clock division factor 32			
0		1		10	Not allowed			
0		1		11	Not allowed			
0		0	OFF, normal mode	00	DSP clock division factor 8	0 to 7/(2Fs) by 1/(2Fs) steps	Fs/4	Refer to <a href="#">Section 5.6</a>
0		0		01	DSP clock division factor 16			
0		0		10	Not allowed			
0		0		11	Not allowed			
1	2:1	1	ON	00	DSP clock division factor 8	0 to 7/(2Fs) by 1/(2Fs) steps	Fs/4	Not recommended mode, not guaranteed
1		1		01	DSP clock division factor 16			
1		1		10	Not allowed			
1		1		11	Not allowed			
1		0	OFF, normal mode	00	DSP clock division factor 4	0 to 7/(2Fs) by 1/(2Fs) steps	Fs/2	Refer to <a href="#">Section 5.6</a>
1		0		01	DSP clock division factor 8			
1		0		10	Not allowed			
1		0		11	Not allowed			

Note: Behaviour according to MUX, OCDS and PSS combination is independent of output mode (MODE).  
For operation in OCDS [10], please contact hotline-bdc@e2v.com

## 5.9 Synchronization Functions for Multi-DAC Operation

In order to synchronize the timings, a SYNC operation can be generated.

After the application of the SYNC signal the DSP clock from the DAC will stop for a period and after a constant and known time the DSP clock will start up again.

There are two SYNC functions integrated in this DAC:

- a power up reset, which is triggered by the power supplies if the dedicated power up sequence is applied  $V_{ccd} \Rightarrow V_{cca3} \Rightarrow V_{cca5}$ ;
- External SYNC pulse applied on (SYNC, SYNCN).

The external SYNC is LVDS compatible (same buffer as for the digital input data). It is active high.

Depending on the settings for OCDS, PSS and also the MUX ratio the width of the SYNC pulse must be greater than a certain number of external clock pulses. It is also necessary that the sync pulse be synchronized with the system clock and is an integer number of clock pulses. See application note (ref 1087) for further details.

**Figure 5-16.** Reset Timing Diagram (4:1 MUX)

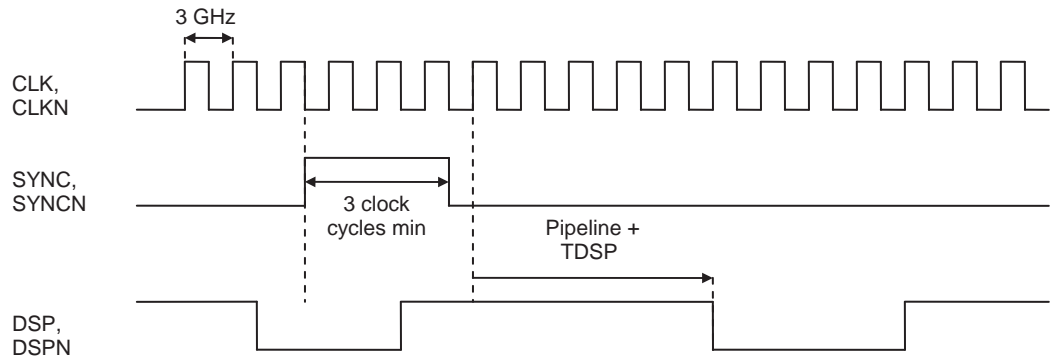

**Figure 5-17.** Reset Timing Diagram (2:1 MUX)

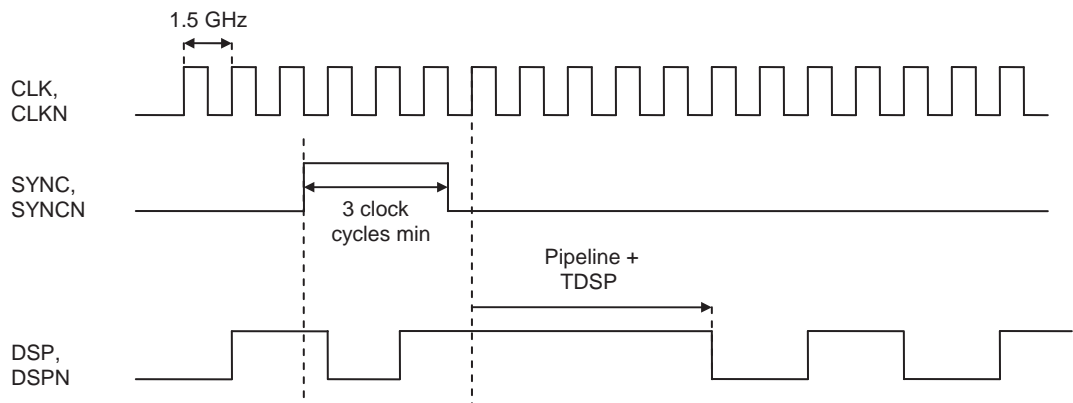

**Important note:**

**For EV10DS130A:**

- See erratasheet (ref 1125) for SYNC condition of use.
- SYNC, SYNCN pins have to be driven.

**For EV10DS130B:**

- SYNC, SYNCN pins can be left floating if unused.
- No specific timing constraints (other than T1 and T2) are required.

**5.10 Gain Adjust GA Function**

This function allows to adjust the internal gain of the DAC to cancel the initial gain deviation.

The gain of the DAC can be adjusted by  $\pm 11\%$  by tuning the voltage applied on GA by varying GA potential from 0 to  $V_{CCA3}$ .

GA max is given for  $GA = 0$  and GA min for  $GA = V_{CCA3}$

## 5.11 Diode Function

A diode is available to monitor the die junction temperature of the DAC.

For the measurement of die junction temperature, a temperature sensor (such as ADM1032) can be used.

**Figure 5-18.** Temperature DIODE Implementation

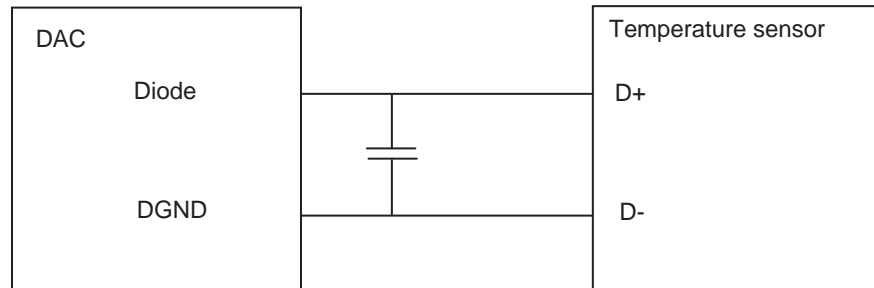

In characterization measurement a current of 1 mA is applied on the DIODE pin. The voltage across the DIODE pin and the DGND pin gives the junction temperature using the intrinsic diode characteristics below [Figure 5-19](#).

**Figure 5-19.** Diode Characteristics for Die Junction Monitoring

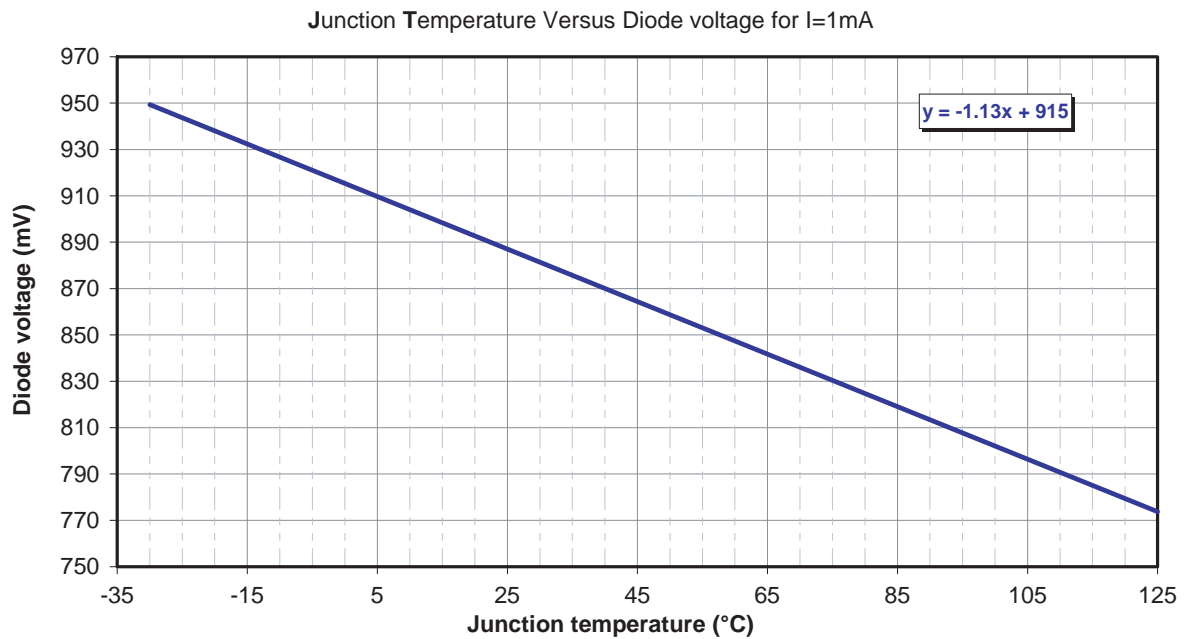



## 6. PIN DESCRIPTION

Figure 6-1. Pinout View (Top View)

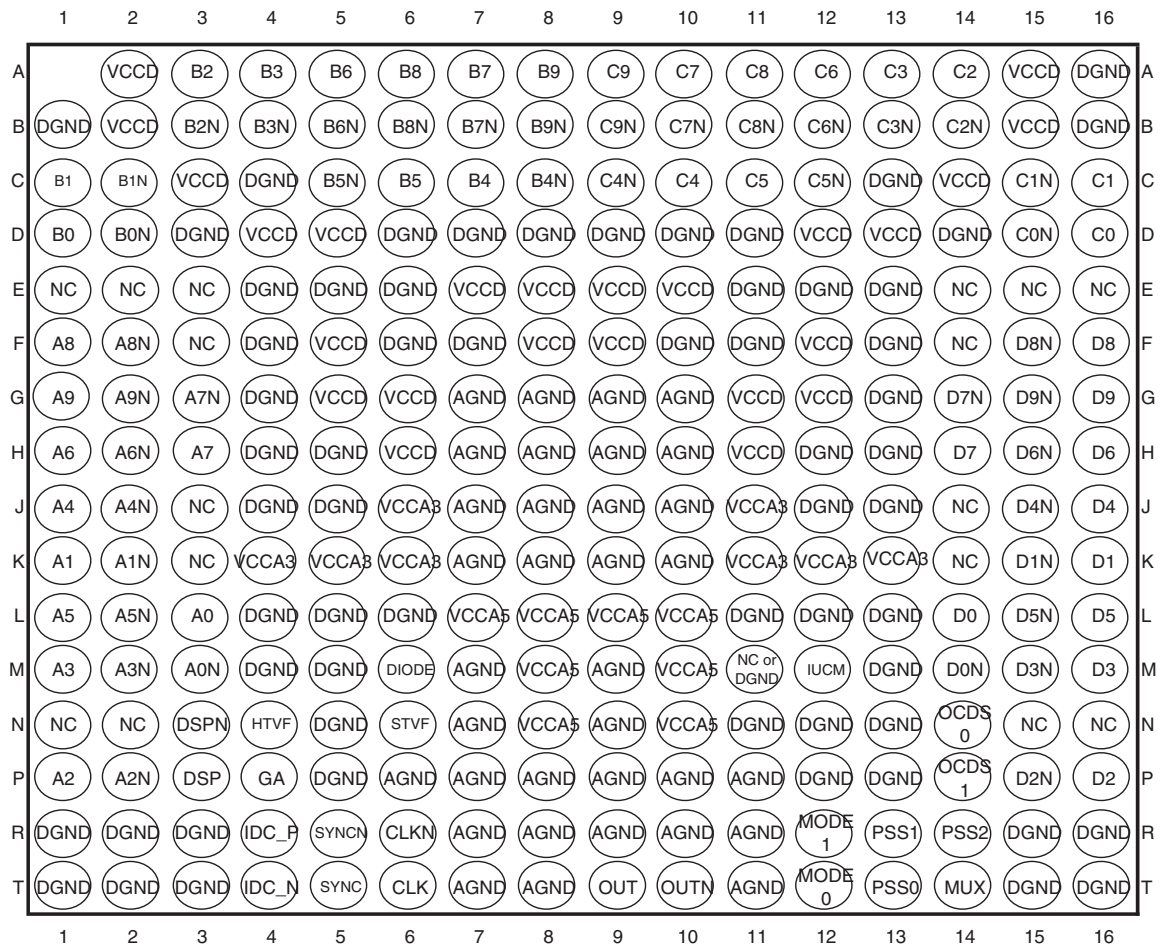

Table 6-1. Pinout Table

Signal Name	Pin number	Description	Direction	Equivalent simplified schematics
<b>Power supplies</b>				
VCCA5	L7, L8, L9, L10, M8, M10, N8, N10	5.0V analog power supplies Referenced to AGND		
VCCA3	J6, J11, K4, K5, K6, K11, K12, K13	3.3V analog power supply Referenced to AGND	NA	
VCCD	A2, A15, B2, B15, C3, C14, D4, D5, D12, D13, E7, E8, E9, E10, F5, F8, F9, F12, G5, G6, G11, G12, H6, H11	3.3V digital power supply Referenced to DGND	NA	
AGND	G7, G8, G9, G10, H7, H8, H9, H10, J7, J8, J9, J10, K7, K8, K9, K10, M7, M9, N7, N9, P6, P7, P8, P9, P10, P11, R7, R8, R9, R10, R11, T7, T8, T11	Analog Ground	NA	

**Table 6-1.** Pinout Table (Continued)

Signal Name	Pin number	Description	Direction	Equivalent simplified schematics
DGND	A16, B1, B16, C4, C13, D3, D6, D7, D8, D9, D10, D11, D14, E4, E5, E6, E11, E12, E13, F4, F6, F7, F10, F11, F13, G4, G13, H4, H5, H12, H13, J4, J5, J12, J13, L4, L5, L6, L11, L12, L13, M4, M5, M13, N5, N11, N12, N13, P5, P12, P13, R1, R2, R3, R15, R16, T1, T2, T3, T15, T16	Digital Ground	NA	
<b>Clock Signals</b>				
CLK, CLKN	T6, R6	Sampling clock signal input (In-phase and inverted phase)	I	
DSP, DSPN	P3, N3	Output clock (in-phase and inverted phase)	O	
<b>Analog Output Signal</b>				
OUT, OUTN	T9, T10	In phase and inverted phase analog output signal (differential termination required)	O	

**Table 6-1.** Pinout Table (Continued)

Signal Name	Pin number	Description	Direction	Equivalent simplified schematics
<b>Digital Input Signals</b>				
A0, A0N A1, A1N A2, A2N A3, A3N A4, A4N A5, A5N A6, A6N A7, A7N A8, A8N A9, A9N	L3, M3 K1, K2 P1, P2 M1, M2 J1, J2 L1, L2 H1, H2 H3, G3 F1, F2 G1, G2	In-phase, inverted phase Digital input Port A Data A0, A0N is the LSB Data A9, A9N is the MSB	I	
B0, B0N B1, B1N B2, B2N B3, B3N B4, B4N B5, B5N B6, B6N B7, B7N B8, B8N B9, B9N	D1, D2 C1, C2 A3, B3 A4, B4 C7, C8 C6, C5 A5, B5 A7, B7 A6, B6 A8, B8	In-phase, inverted phase Digital input Port B Data B0, B0N is the LSB Data B9, B9N is the MSB	I	
C0, C0N C1, C1N C2, C2N C3, C3N C4, C4N C5, C5N C6, C6N C7, C7N C8, C8N C9, C9N	D16, D15 C16, C15 A14, B14 A13, B13 C10, C9 C11, C12 A12, B12 A10, B10 A11, B11 A9, B9	In-phase, inverted phase Digital input Port D Data D0, D0N is the LSB Data D9, D9N is the MSB	I	
D0, D0N D1, D1N D2, D2N D3, D3N D4, D4N D5, D5N D6, D6N D7, D7N D8, D8N D9, D9N	L14, M14 K16, K15 P16, P15 M16, M15 J16, J15 L16, L15 H16, H15 H14, G14 F16, F15 G16, G15	In-phase, inverted phase Digital input Port D Data D0, D0N is the LSB Data D9, D9N is the MSB	I	
IDC_P IDC_N	R4 T4	Input data check	I	
SYNC, SYNCN	T5, R5	In phase and Inverted phase reset signal	I	

**Table 6-1.** Pinout Table (Continued)

Signal Name	Pin number	Description	Direction	Equivalent simplified schematics
<b>Control Signals</b>				
HTVF	N4	Setup time violation flag	O	
STVF	N6	Hold time violation flag	O	
PSS0 PSS1 PSS2	T13 R13 R14	Phase Shift Select (PSS2 is the MSB)	I	
MODE0 MODE1	T12 R12	DAC Mode selection bits: - RTZ - NRZ - Narrow RTZ - RF	I	
OCDS0 OCDS1	N14 P14	Output Clock Division Select = these bits allow to select the clock division factor applied on the DSP, DSPN signal.	I	
MUX	T14	MUX selection:	I	
IUCM	M12	Input underclocking mode enable	I	
GA	P4	Gain adjust	I	

**Table 6-1.** Pinout Table (Continued)

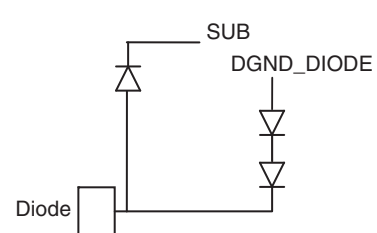
Signal Name	Pin number	Description	Direction	Equivalent simplified schematics
Diode	M6	Diode for die junction temperature monitoring function	I	
NC	E1, E2, E3, E14, E15, E16, F3, F14, J3, J14, K3, K14, M11, N1, N2, N15, N16	Reserved pin, NC, can be connected to DGND		

## 7. APPLICATION INFORMATION

For further details, please refer to application note 1087.

### 7.1 Analog Output (OUT/OUTN)

The analog output should be used in differential way as described in the figures below.

If the application requires a single-ended analog output, then a balun is necessary to generate a single-ended signal from the differential output of the DAC.

**Figure 7-1.** Analog Output Differential Termination

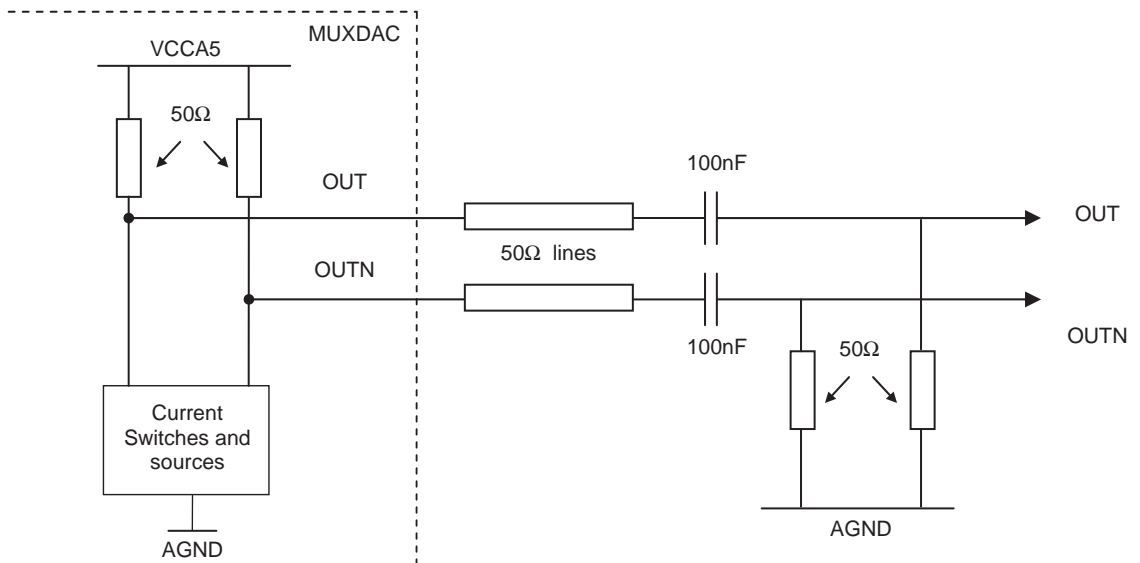

**Figure 7-2.** Analog Output Using a  $1/\sqrt{2}$  Balun

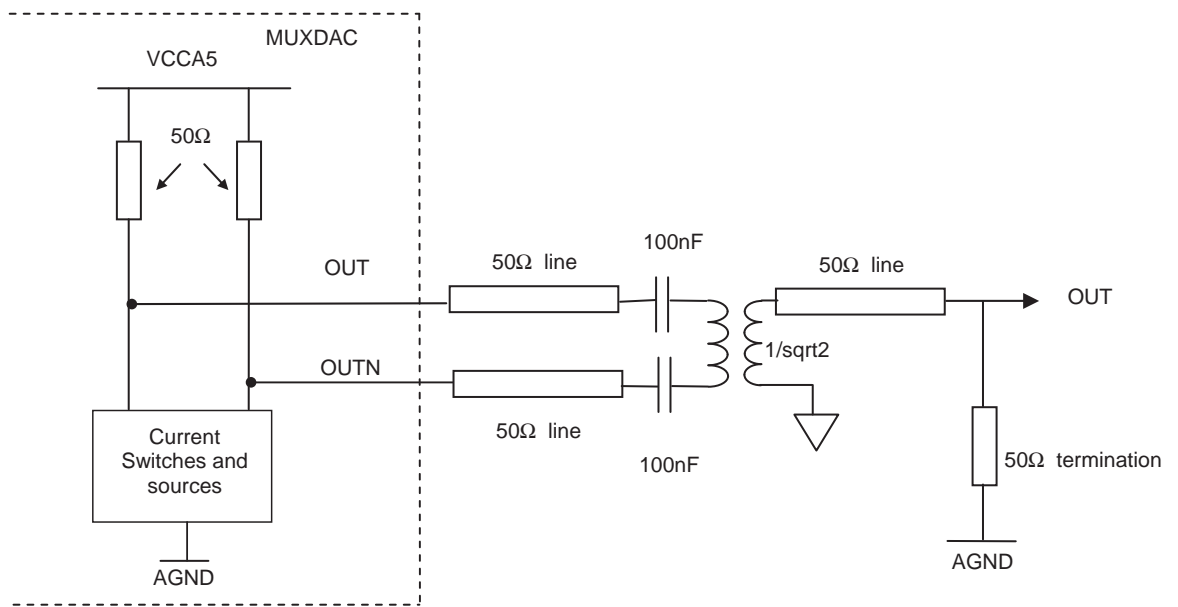

Note: The AC coupling capacitors should be chosen as broadband capacitors with a value depending on the application.

## 7.2 Clock Input (CLK/CLKN)

The DAC input clock (sampling clock) should be entered in differential mode as described in [Figure 7-3](#).

**Figure 7-3.** Clock Input Differential Termination

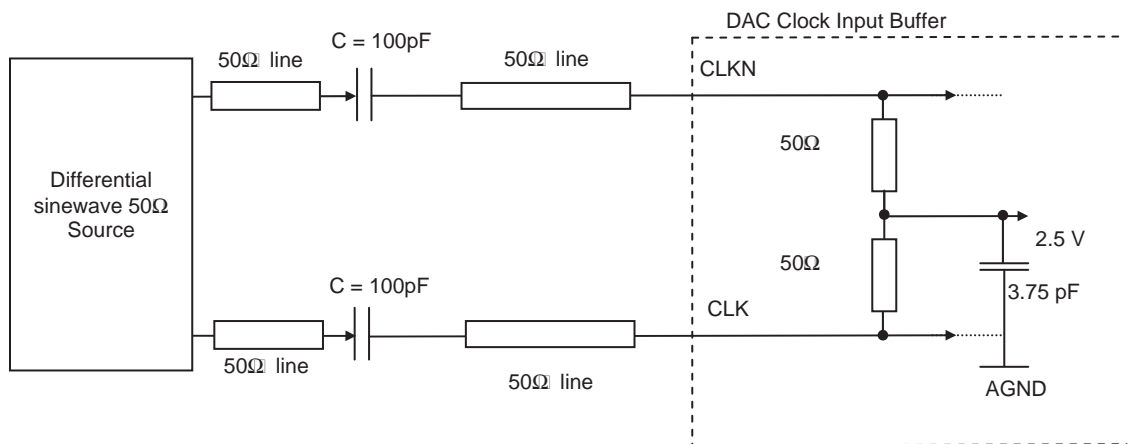

Note: The buffer is internally pre-polarized to 2.5V (buffer between  $V_{CCA5}$  and AGND).

**Figure 7-4.** Clock Input Differential with Balun

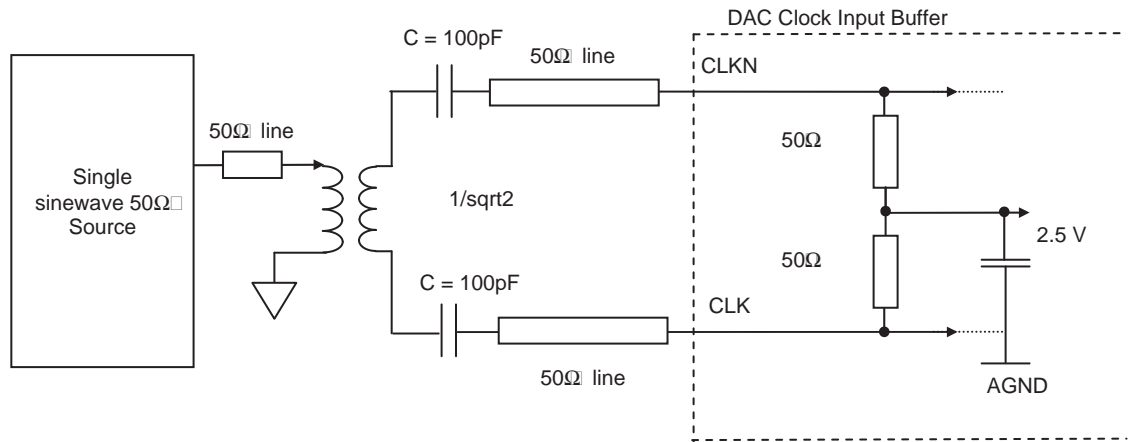

Note: The AC coupling capacitors should be chosen as broadband capacitors with a value depending on the application.

### 7.3 Digital Data, SYNC and IDC Inputs

LVDS buffers are used for the digital input data, the reset signal (active high) and IDC signal. They are all internally terminated by  $2 \times 50\Omega$  to ground via a 3.75 pF capacitor.

**Figure 7-5.** Digital Data, Reset and IDC Input Differential Termination

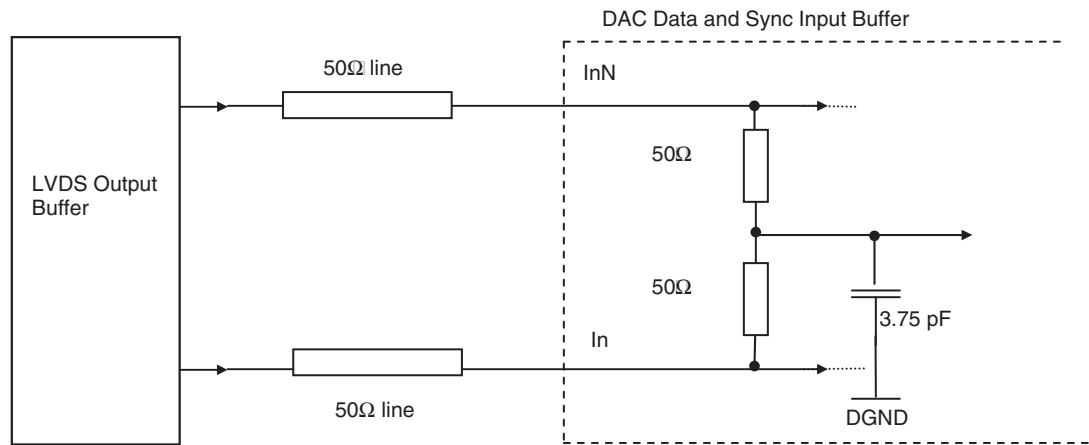

- Notes:
1. In the case when only two ports are used (2:1 MUX ratio), then the unused data should be left open (no connect).
  2. Data and IDC signals should be routed on board with the same layout rules and the same length than the data.
  3. In the case, the SYNC is not used, it is necessary to bias the SYNC to 1.1V and SYNCN to 1.4V on EV10DS130A

## 7.4 DSP Clock

The DSP, DSPN output clock signals are LVDS compatible.

They have to be terminated via a differential 100Ω termination as described in [Figure 7-6](#).

**Figure 7-6.** DSP Output Differential Termination

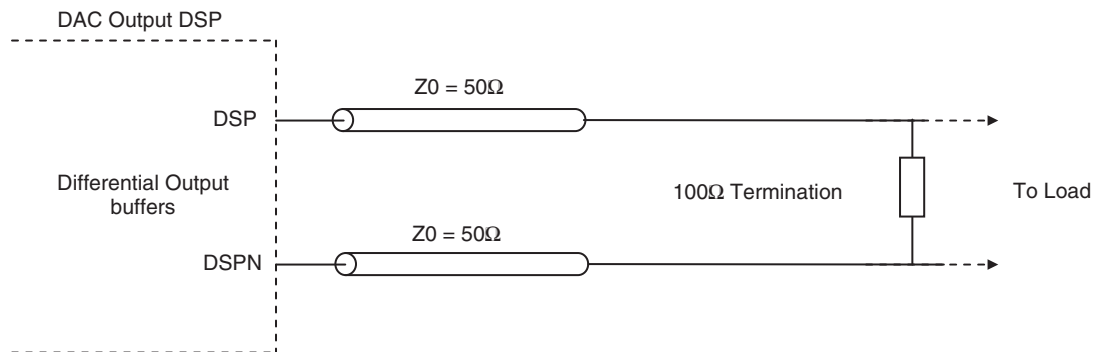

## 7.5 Control Signal Settings

The MUX, MODE, PSS and OCDS control signals use the same static input buffer.

Logic "1" = 200 KΩ to Ground, or tied to  $V_{CCD} = 3.3V$  or left open

Logic "0" = 10Ω to Ground or Grounded

**Figure 7-7.** Control Signal Settings

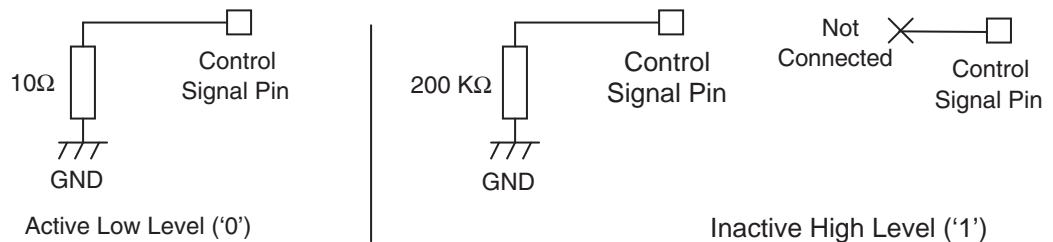

The control signal can be driven by FPGA.

**Figure 7-8.** Control Signal Settings with FPGA



Logic "1" >  $V_{IH}$  or  $V_{CCD} = 3.3V$

Logic "0" <  $V_{IL}$  or 0V



## 7.6 HTVF and STVF Control Signal

The HTVF and STVF control signals is a output 3.3V CMOS buffer.

These signals could be acquired by FPGA.

**Figure 7-9.** Control Signal Settings with FPGA

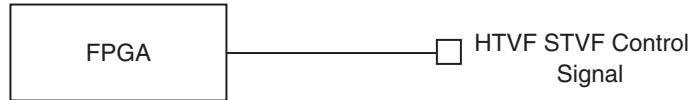

In order to modify the  $V_{OL}/V_{OH}$  value, pull up and pull down resistances could be used, or a potential divider.

## 7.7 GA Function Signal

This function allows adjustment of the internal gain of the DAC.

The gain of the DAC can be tuned with applied analog voltage from 0 to  $V_{CCA3}$

This analog input signal could be generated by a DAC control by FPGA or microcontroller.

**Figure 7-10.** Control Signal Settings with GA



## 7.8 Power Supplies Decoupling and Bypassing

The DAC requires 3 distinct power supplies:

$V_{CCA5} = 5.0V$  (for the analog core)

$V_{CCA3} = 3.3V$  (for the analog part)

$V_{CCD} = 3.3V$  (for the digital part)

It is recommended to decouple all power supplies to ground as close as possible to the device balls with 100 pF in parallel to 10nF capacitors. The minimum number of decoupling pairs of capacitors can be calculated as the minimum number of groups of neighbouring pins.

4 pairs of 100pF in parallel to 10 nF capacitors are required for the decoupling of  $V_{CCA5}$ . 4 pairs for the  $V_{CCA3}$  is the minimum required and finally, 10 pairs are necessary for  $V_{CCD}$ .

**Figure 7-11.** Power Supplies Decoupling Scheme

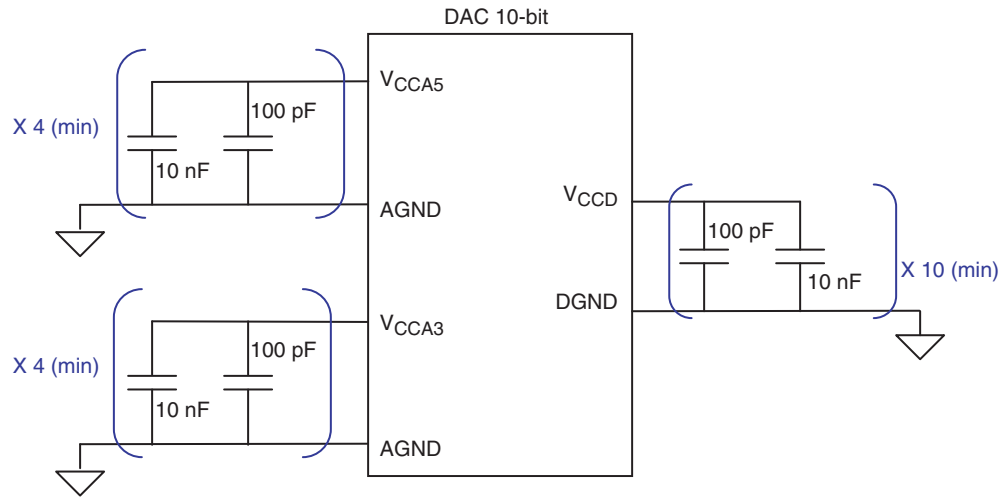

Each power supply has to be bypassed as close as possible to its source or access by 100 nF in parallel to 22  $\mu$ F capacitors (value depending of DC/DC regulators).

Analog and digital ground plane should be merged.

## 7.9 Power Up Sequencing

**For EV10DS130B there is no forbidden power-up sequence, nor power supplies dependency requirement.**

**For EV10DS130A the following instructions must be implemented:**

Power-up sequence:

It is necessary to raise  $V_{CCA5}$  power supply within the range 5.20V up to a recommended maximum of 5.60V during at least 1ms at power up. Then the supply voltage has to settle within 500 ms to a steady nominal supply voltage within a range of 4.75V up to 5.25V.

A power-up sequence on  $V_{CCA5}$  that does not comply with the above recommendation will not compromise the functional operation of the device. Only the noise floor will be affected.

**Figure 7-12. Power-up Sequence**

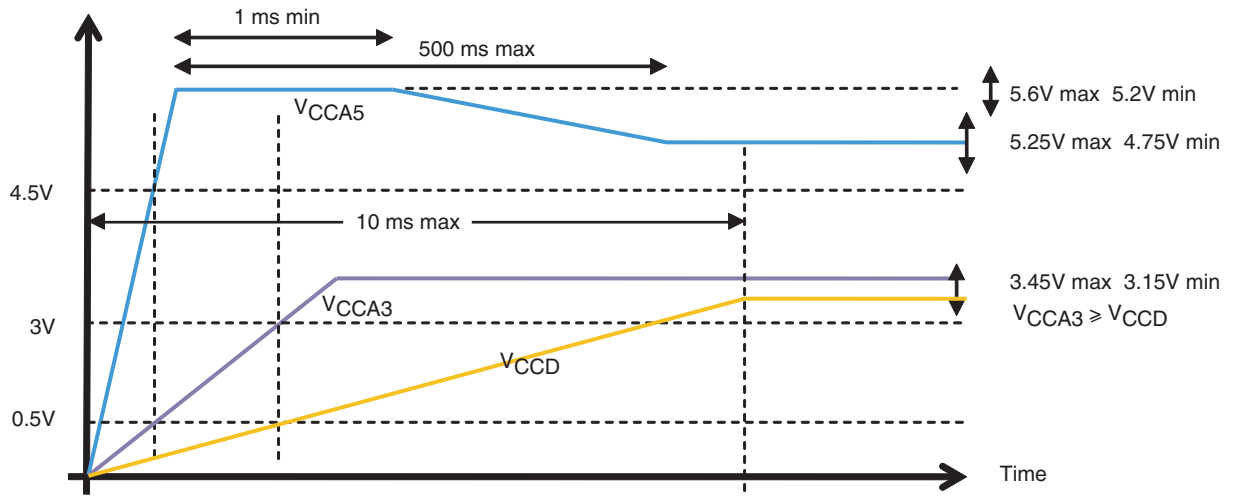

The rise time for any of the power supplies ( $V_{CCA5}$ ,  $V_{CCA3}$  and  $V_{CCD}$ ) shall be  $\leq 10$  ms.

At power-up a SYNC pulse is internally and automatically generated when the following sequence is satisfied:  $V_{CCD}$ ,  $V_{CCA3}$  and  $V_{CCA5}$ . To cancel the SYNC pulse at power-up, it is necessary to apply the sequence:  $V_{CCA5}$ ,  $V_{CCA3}$ ,  $V_{CCD}$ . ( $V_{CCA3}$  can not reach 0.5V until  $V_{CCA5}$  is greater than 4.5V.  $V_{CCD}$  can not reach 0.5V until  $V_{CCA3}$  is greater than 3.0V). Any other sequence may not have a deterministic SYNC behaviour. See erratasheet (ref 1125) for specific condition of use relative to the SYNC operation.

Relationship between power supplies:

Within the applicable power supplies range, the following relationship shall always be satisfied  $V_{CCA3} \geq V_{CCD}$ , taking into account AGND and DGND planes are merged and power supplies accuracy.

## 8. PACKAGE DESCRIPTION

### 8.1 Ci-CGA255 Outline

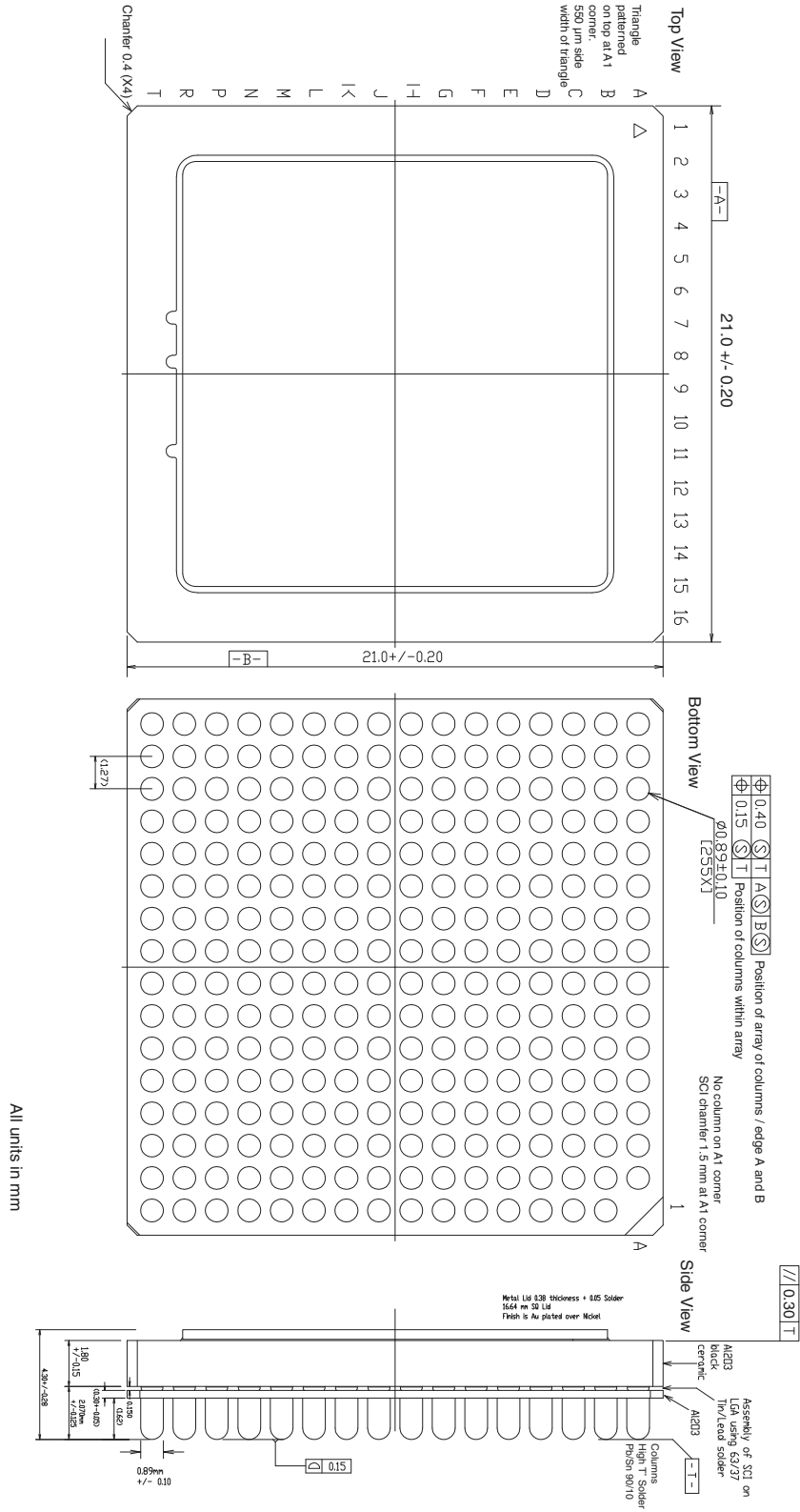

## 8.2 CLGA255 Outline

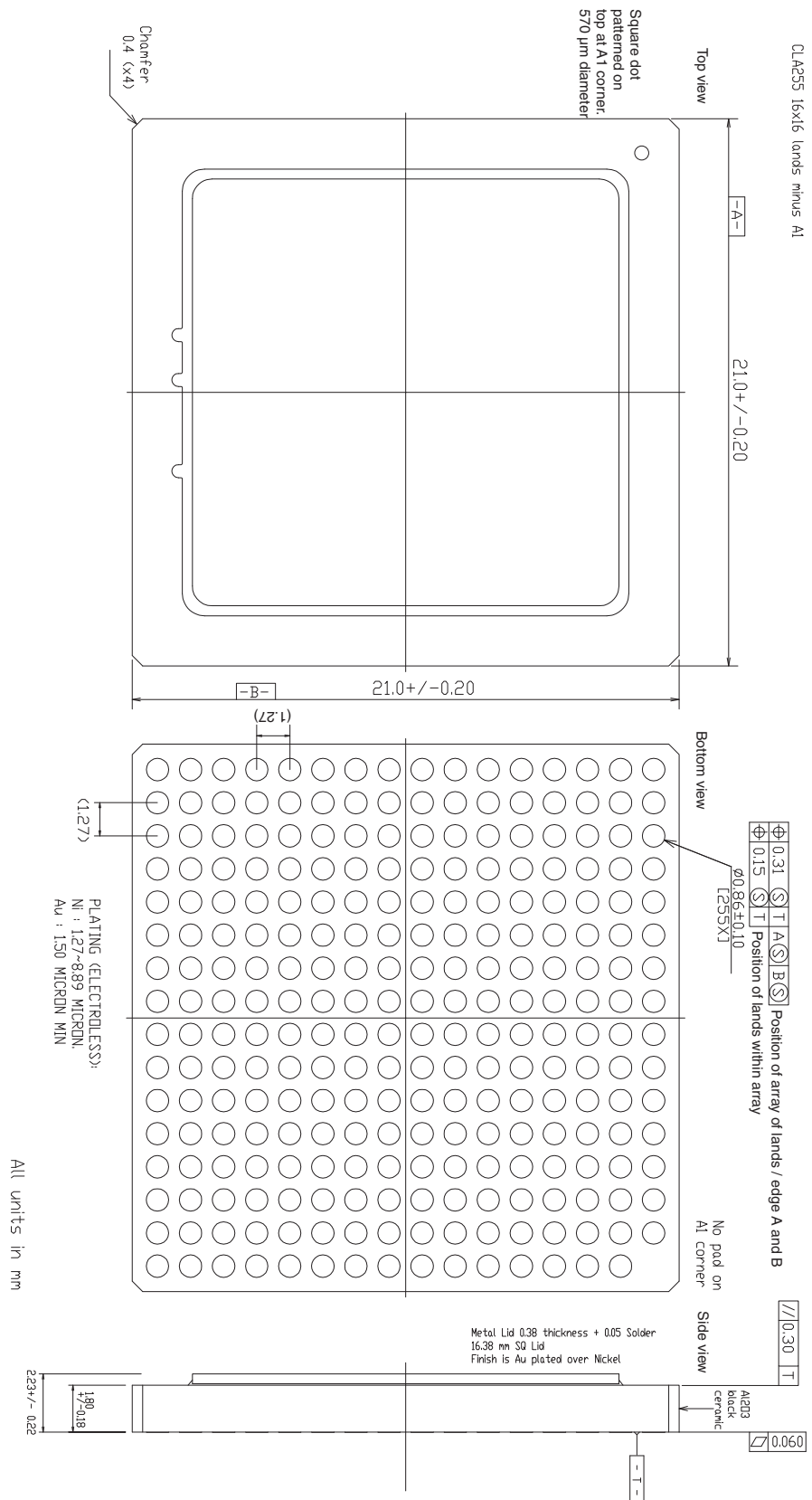

### 8.3 CCGA255 Outline

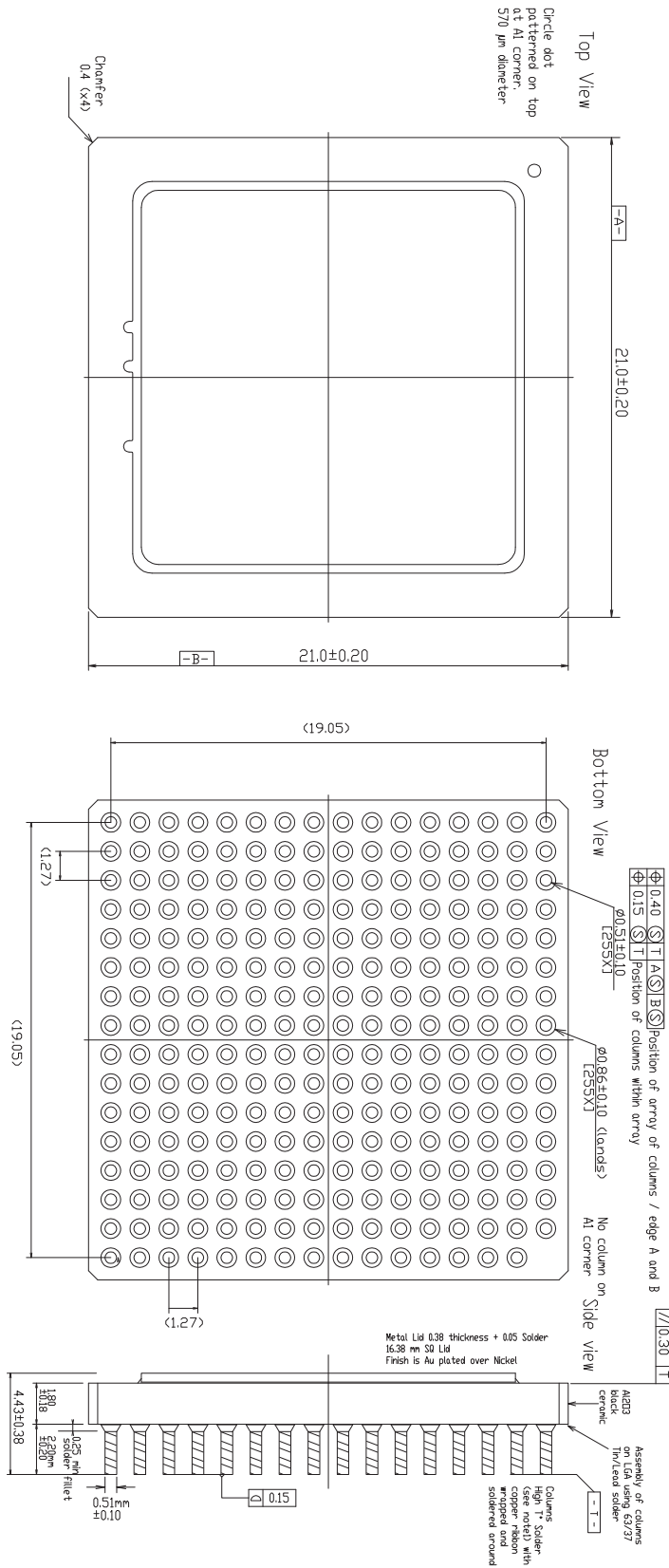

**Note 1**  
 Initial column core composition (prior to column wire manufacturing): Sn20—Pb80 (wt %).  
 Final column core composition (after column attach on CPGA packages): 55 ≤ Pb wt% ≤ 80

All units in mm

## 8.4 Thermal Characteristics

Assumptions:

- Die thickness = 300  $\mu\text{m}$
- No convection
- Pure conduction
- No radiation

$R_{TH}$	Heating zone	Ci CGA	CCGA	Unit
Junction-> Bottom of columns	7.5% die area : 4580x4580 $\mu\text{m}$	13.8	15.0	$^{\circ}\text{C}/\text{W}$
Junction-> Board ( JEDEC JESD51-8) Boad size = 39x39mm, 1.6 mm Thickness)		17.1	18.6	$^{\circ}\text{C}/\text{W}$
Junction -> Top of Lid		19.3	22.0	$^{\circ}\text{C}/\text{W}$
$T_{jhot\ spot} - T_{Jdiode}$		3.3	3.3	$^{\circ}\text{C}/\text{W}$

Typical Assumptions:

- Convection according to JEDEC
- Still air
- Horizontal 2s2p board
- Board size 114.3  $\times$  76.2 mm, 1.6 mm thickness

$R_{TH}$	Heating zone	Ci CGA	CCGA	Unit
Junction -> Ambient	18% die area : 4820x4820 $\mu\text{m}$	29.5	29.4	$^{\circ}\text{C}/\text{W}$
$T_{jhot\ spot} - T_{Jdiode}$		3.3	3.3	$^{\circ}\text{C}/\text{W}$

## 9. DIFFERENCES BETWEEN EV10DS130A AND EV10DS130B

EV10DS130A and EV10DS130B exhibit the same dynamic performances.

EV10DS130B requires no specific dependency between power supplies nor power up sequences while the EV10DS130A does require specific power up sequences as described in [Section 7.9 on page 42](#).

Maximum supported sampling frequency with DSP clock feature for EV10DS130B is 2.1GHz due to internal jitter. It is however possible to benefit from the EV10DS130B DAC performances up to 3GHz if specific system architecture is implemented. Please refer to application AN1141 for further information.

No SYNC timing constraints (other than T1 T2) are required on EV10DS130B.

As a summary

When using EV10DS130A, please ensure your system fulfills those specific recommendations

- Power Up Sequence (See [Section 7.9 on page 42](#))
- Power supplies dependency (see [Section 7.9 on page 42](#))
- SYNC pin have to be driven in any case
- Please refer to errata sheet 1125

When using EV10DS130B, please ensure your system fulfills those specific recommendations

- In case sampling frequency is above 2.1 Gsp/s, please read the AN1141 “Using EV1xDS130B at sampling rate higher than 2.1GSp/s”

Please refer to application note AN1140 "Replacing EV1xDS130A with EV1xDS130B" for further details

## 10. ORDERING INFORMATION

**Table 10-1.** Ordering Information

Part Number	SMD Number	Package	Temperature Range	Screening Level	Comments
<b>EV10DS130A</b>					
EVX10DS130AGS		CI-CGA255	Ambient	Prototype	
EV10DS130AMGSD/T		CI-CGA255	-55°C < Tc,Tj < 125°C	EQM Grade	
EV10DS130AMGS9NB1		CI-CGA255	-55°C < Tc,Tj < 125°C	Space Grade	
EV10DS130AGS-EB		CI-CGA255	Ambient	Prototype	Evaluation board
<b>EV10DS130B</b>					
EVX10DS130BGS		CI-CGA255	Ambient	Prototype	
EV10DS130BMGS		CI-CGA255	-55°C < Tc,Tj < 125°C	Engineering model	
EV10DS130BMGSD/T		CI-CGA255	-55°C < Tc,Tj < 125°C	EQM Grade	
EV10DS130BMGS9NB1		CI-CGA255	-55°C < Tc,Tj < 125°C	Space Grade	
EV10DS130BGS-EB		CI-CGA255	Ambient	Prototype	Evaluation board
EV10DS130AMLG-V	5962-1522101VXC	CLGA255	-55°C < Tc,Tj < 125°C	QML-V Grade MIL PRF 38535	
EV10DS130AMGS-V	5962-1522101VYF	CI-CGA255	-55°C < Tc,Tj < 125°C	QML-V Grade MIL PRF 38535	
EV10DS130AMGC-V	5962-1522101VZF	CCGA255	-55°C < Tc,Tj < 125°C	QML-V Grade MIL PRF 38535	



## 11. REVISION HISTORY

This table provides revision history for this document.

**Table 11-1.** Revision History

Rev. No	Date	Substantive Change(s)
1090E	January 2018	<a href="#">Table 10-1, "Ordering Information," on page 48</a> : Remove "Pending qualification / contact Marketing" in the Comments column
1090D	November 2015	Introduction of QML-V grade
1090C	December 2014	<p><a href="#">Section 5.6 on page 27</a>: OCDS [10] not allowed</p> <p>Introduction and description of EV10DS130B</p> <p>New <a href="#">Section 9. "Differences between EV10DS130A and EV10DS130B" on page 47</a></p> <p><a href="#">Section 5.1 "DSP Output Clock" on page 17</a> updated</p> <p><a href="#">Section 5.3 "MODE Function" on page 17</a>: equations updated</p> <p><a href="#">Section 5.5 "PSS (Phase Shift Select Function)" on page 25</a> updated</p> <p><a href="#">Section 5.9 "Synchronization Functions for Multi-DAC Operation" on page 30</a> updated</p> <p><a href="#">Table 10-1, "Ordering Information," on page 48</a> added column Lead Finish and added part number EV10DS130AVZP and all EV10DS130B part numbers</p>
1090B	May 2014	<p>Full modification of the datasheet to have the same format as EV10DS130A datasheet 1080F</p> <p>Main modifications concerns:</p> <p><a href="#">Table 3-1</a>: Change of VCCA3 ,VCCD and Digital input max ratings + add ESD max ratings</p> <p><a href="#">Section 3.2 on page 4</a>: modification of power up sequencing</p> <p><a href="#">Table 3-3</a> : Change max current ICCD limit (2:1 &amp; 4:1 MUX mode)</p> <p><a href="#">Table 3-3</a> : Add input current specification on digital inputs</p> <p><a href="#">Table 3-3</a>: Output internal differential resistor is test level 1 &amp; 6</p> <p><a href="#">Table 3-6</a>: remove minimum limit on  SFDR  in 4:1 MUX mode <math>F_s = 3\text{Gsp}</math>s @ <math>F_{out} = 1600\text{MHz}</math> 0 dBFS (now test level 4)</p> <p><a href="#">Table 3-6</a>: remove maximum limit on highest spur level in 4:1 MUX mode <math>F_s = 3\text{Gsp}</math>s @ <math>F_{out} = 1600\text{MHz}</math> 0 dBFS (now test level 4)</p> <p><a href="#">Table 3-8</a>: provide min &amp; max limits for Input data rate in 2:1 and 4:1 MUX mode.</p> <p><a href="#">Table 3-8</a>: Delay TPD is renamed TPD. It is a typ value and not a max value</p> <p><a href="#">Table 3-8</a>: Add SYNC forbidden area timing values and timing diagram</p> <p>Add chap on definition of terms</p> <p><a href="#">Table 5-3</a> and <a href="#">Table 5-5</a>: OCDS restriction</p> <p><a href="#">Figure 7-11</a>: modification of power supplies decoupling scheme on VCCA3 and VCCD</p> <p>Typo corrections</p> <p><a href="#">Section 7.9 on page 42</a>- Modification of Power Up sequencing</p> <p><a href="#">Section 8. on page 44</a> - Add CCGA package with Six Sigma Columns + Rth adjustments</p>
1090A	July 2012	Initial Revision



# Table of Contents

	<b>MAIN FEATURES .....</b>	<b>1</b>
	<b>PERFORMANCES .....</b>	<b>1</b>
	<b>APPLICATIONS .....</b>	<b>1</b>
<b>1</b>	<b>Block Diagram .....</b>	<b>2</b>
<b>2</b>	<b>Description .....</b>	<b>2</b>
<b>3</b>	<b>Electrical Characteristics .....</b>	<b>3</b>
	3.1 Absolute Maximum Ratings .....	3
	3.2 Recommended Conditions of Use .....	4
	3.3 Electrical Characteristics .....	5
	3.4 AC Electrical Characteristics .....	7
	3.5 Timing Characteristics and Switching Performances .....	12
	3.6 Explanation of Test Levels .....	14
	3.7 Digital Input Coding Table .....	14
<b>4</b>	<b>Definition of Terms .....</b>	<b>15</b>
<b>5</b>	<b>Functional Description .....</b>	<b>16</b>
	5.1 DSP Output Clock .....	17
	5.2 Multiplexer .....	17
	5.3 MODE Function .....	17
	5.4 Input Under Clocking Mode (IUCM), Principle and Spectral Response .....	23
	5.5 PSS (Phase Shift Select Function) .....	25
	5.6 Output Clock Division Select Function .....	27
	5.7 Synchronization FPGA-DAC: IDC_P, IDC_N, HTVF and STVF Functions .....	28
	5.8 OCDS, IUCM, MUX Combinations Summary .....	30
	5.9 Synchronization Functions for Multi-DAC Operation .....	30
	5.10 Gain Adjust GA Function .....	31
	5.11 Diode Function .....	32
<b>6</b>	<b>PIN Description .....</b>	<b>33</b>
<b>7</b>	<b>Application Information .....</b>	<b>37</b>
	7.1 Analog Output (OUT/OUTN) .....	37
	7.2 Clock Input (CLK/CLKN) .....	38
	7.3 Digital Data, SYNC and IDC Inputs .....	39

7.4	DSP Clock .....	40
7.5	Control Signal Settings .....	40
7.6	HTVF and STVF Control Signal .....	41
7.7	GA Function Signal .....	41
7.8	Power Supplies Decoupling and Bypassing .....	41
7.9	Power Up Sequencing .....	42
<b>8</b>	<b><i>Package Description</i></b> .....	<b>44</b>
8.1	Ci-CGA255 Outline .....	44
8.2	CLGA255 Outline .....	45
8.3	CCGA255 Outline .....	46
8.4	Thermal Characteristics .....	47
<b>9</b>	<b><i>Differences between EV10DS130A and EV10DS130B</i></b> .....	<b>47</b>
<b>10</b>	<b><i>Ordering Information</i></b> .....	<b>48</b>
<b>11</b>	<b><i>Revision History</i></b> .....	<b>49</b>