

# Rad-icon Imaging Corp

3193 Belick Street, Unit 1  
Santa Clara, CA 95054-2404

tel 408-486-0886  
fax 408-486-0882

---

## AN04: Imaging with Pulsed X-Ray Sources

### Introduction

In many x-ray imaging applications the x-ray source is always turned on. This is often referred to as a *fluoroscopy* or *continuous mode*, and also happens to correspond to the default imaging mode of the RadEye image sensor and the Shad-o-Box cameras. In the continuous mode, the imager and camera constantly deliver image frames to the data acquisition system or frame grabber. The timing, or frame rate, is determined only by the master clock, and the end of one frame readout sequence immediately triggers the start of the next one.

The main advantage of the continuous mode is that it is very simple to set up since it doesn't require any synchronization between the various parts of the x-ray imaging system. The x-ray image is constant, and the frame grabber simply grabs the next available frame whenever it needs to update the screen display. However, there are situations where this mode can't be used, such as when the power dissipation in the x-ray tube only permits short x-ray pulses, or when the exposure to the imaged object needs to be minimized.

Pulsed imaging applications require careful synchronization between the x-ray source, the imager, and the data acquisition system. The imager has to be controlled so that its readout cycle is idle when the x-ray source is pulsed, and the data acquisition system has to be triggered so that it acquires the frame that was actually exposed, and not the one before or after it. In this application note we intend to provide some ideas on designing a pulsed imaging system with the RadEye imager or a Shad-o-Box camera. Of course, there are many possible solutions, and each application is slightly different. We hope to provide enough information to get you started taking images with your pulsed x-ray system. Before proceeding, please take a moment to familiarize yourself with the RadEye and Shad-o-Box datasheets. A basic understanding of the device functionality is expected during the following discussion.

### Shad-o-Box Camera

We will first discuss the requirements for a pulsed x-ray system that uses the Shad-o-Box camera with a digital frame grabber and the ShadoCam imaging software. The Shad-o-Box camera operates either in *continuous mode* or in *frame mode*. The latter requires an external sync pulse either from the frame grabber or from another source.

#### 1. Manual Operation

Manual operation assumes that the x-ray pulse is triggered by pressing or releasing a button on the x-ray control panel. Sometimes the source has to be armed before it can be triggered. The exposure is determined by the pulse width control or mA/mAs settings on the x-ray control panel.

In the manual mode the operator has to provide the synchronization between x-ray source, camera and frame grabber. To properly time the x-ray pulses, the operator needs to know when the camera is transferring image data to the frame grabber. During this readout interval, the camera electronics scan the imager row by row, resetting each pixel in the process. The x-ray pulse needs to be timed to occur in the *blanking interval* between readout sequences. Fortunately, this blanking interval can be adjusted to just about any length necessary by adjusting the *exposure time* or *frame period* of the camera (select *Frame Exposure* from the *Acquisition Menu* in ShadoCam). The maximum frame period depends on the frame grabber hardware (see Table 1). If a longer frame period is required, an external pulse generator must be used.

A simple method to observe the readout timing of the camera is to connect an LED to the *Frame Sync* output of the camera. The *Frame Sync* signal is a TTL pulse that is high during the readout sequence and low during the blanking

Table 1 – Camera frame period control

	Signal Connection	Min. Frame Period <sup>1</sup>	Max. Frame Period	Pulse Width
Data Translation DT3157	parallel interface (EXSYNC)	440 ms	1.7 sec	n/a
Imagination PXD1000	parallel interface (EXSYNC)	440 ms	6.7 sec	10 ms
External Pulse Generator	SMA connector (Ext. Sync In)	440 ms	60 sec <sup>2</sup>	1-10 ms

<sup>1</sup>Minimum frame period is determined by the length of the image readout sequence.

<sup>2</sup>Maximum frame period is limited by the timeout counter in the ShadoCam software.

interval. Figure 1 shows a diagram of the appropriate signal connections. The LED is connected in series with a small resistor (typ. 100-500 Ohms) directly to the *Frame Sync* output. An optional pulse generator is shown connected to the *Ext. Sync* input. If the external pulse generator is used, make sure to set the frame exposure in ShadoCam to 10 ms or less in order to disable the frame grabber exposure control. The pulse generator should be adjusted to produce a positive TTL pulse with a pulse width between 1 ms and 10 ms. The pulse frequency controls the frame period of the camera.

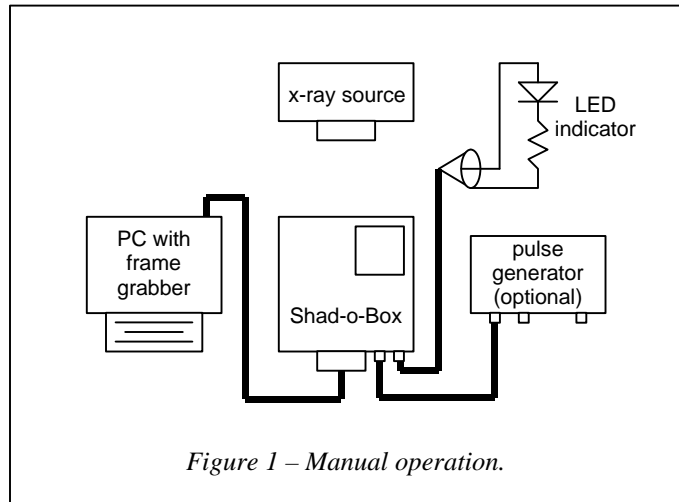
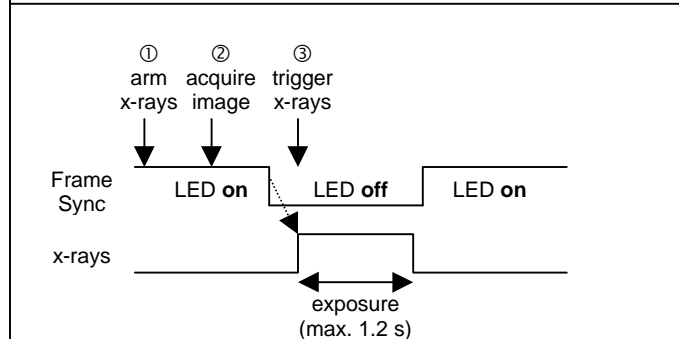
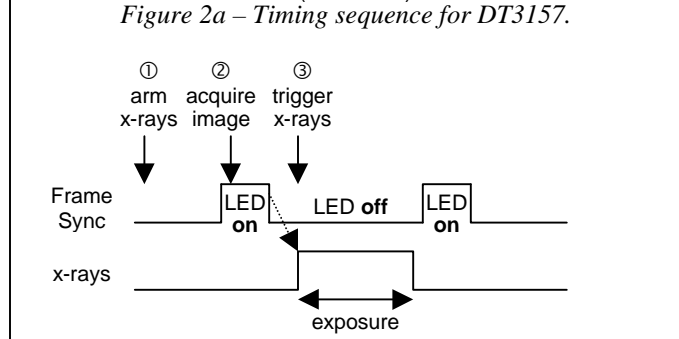

Figure 2 shows the timing sequence for acquiring an x-ray image. The timing for the DT3157 frame grabber is slightly different in that it keeps the camera in continuous readout mode until an image acquisition is requested. Therefore the LED is always **on**, except during the blanking interval following the acquire image command. This is shown in Figure 2a. For the other systems, the camera timing is controlled with a repeating start pulse, causing the LED to turn **on** at regular intervals when the camera is reading out an image (Figure 2b).



The first step in acquiring an image is to arm the x-ray source (if necessary). Next, while the LED is **on**, the operator tells the software to acquire an image (select *Single Image* from the *Acquisition Menu* in ShadoCam). This arms the frame grabber to acquire the next available image. As soon as the LED goes **off**, the operator then triggers the x-ray source. If the frame period is set correctly, the entire x-ray pulse should fall within the current blanking interval and end before the LED turns **on** again to indicate the next readout sequence. The frame grabber then reads the data from the exposed frame and displays the image on the PC monitor.



## 2. Automated Operation

The image acquisition process described above can be automated by using another pulse generator to control the x-ray source. This requires that the x-ray source can be triggered by an external control signal. Figure 3 shows the necessary connections. For the scenario shown in Figure 3a, the camera frame period is controlled by the frame grabber. Instead of driving an LED, the *Frame Sync* output from the camera is used to trigger the pulse generator. The falling edge of *Frame Sync* should be used to initiate the x-ray pulse, again timing it so that it falls within the blanking interval of the camera. If the pulse generator controls both the camera and the x-ray source, the connections shown in Figure 3b should be used. In this case the pulse generator outputs a repeating start pulse to the camera, followed approximately 500 ms later by a trigger pulse for the x-ray source. The timing diagrams for each of these cases are shown in Figure 4.

The automated scenario described here probably needs to be modified to adjust to the specific requirements of the x-ray system being used. The system may still need to be armed manually before an exposure can take place. Also, the trigger pulse for the x-ray source may need to be gated so that the source is activated only when an image is to be taken. Finally, the frame grabber still needs to be triggered manually via software command before the image acquisition takes place. Although most frame grabbers also have a hardware trigger input, the use of this feature is beyond the scope of this discussion.

## 3. Offset and Gain Correction

To obtain the best possible image quality with the Shad-o-Box camera, the built-in offset and gain correction functions in the ShadoCam software should be used. Offset images are easily obtained in any of the imaging modes described above by simply acquiring frames while the x-ray source is turned off. Make sure to use the same integration time for the offset image as for the actual x-ray image so that the dark signal offsets are matched.

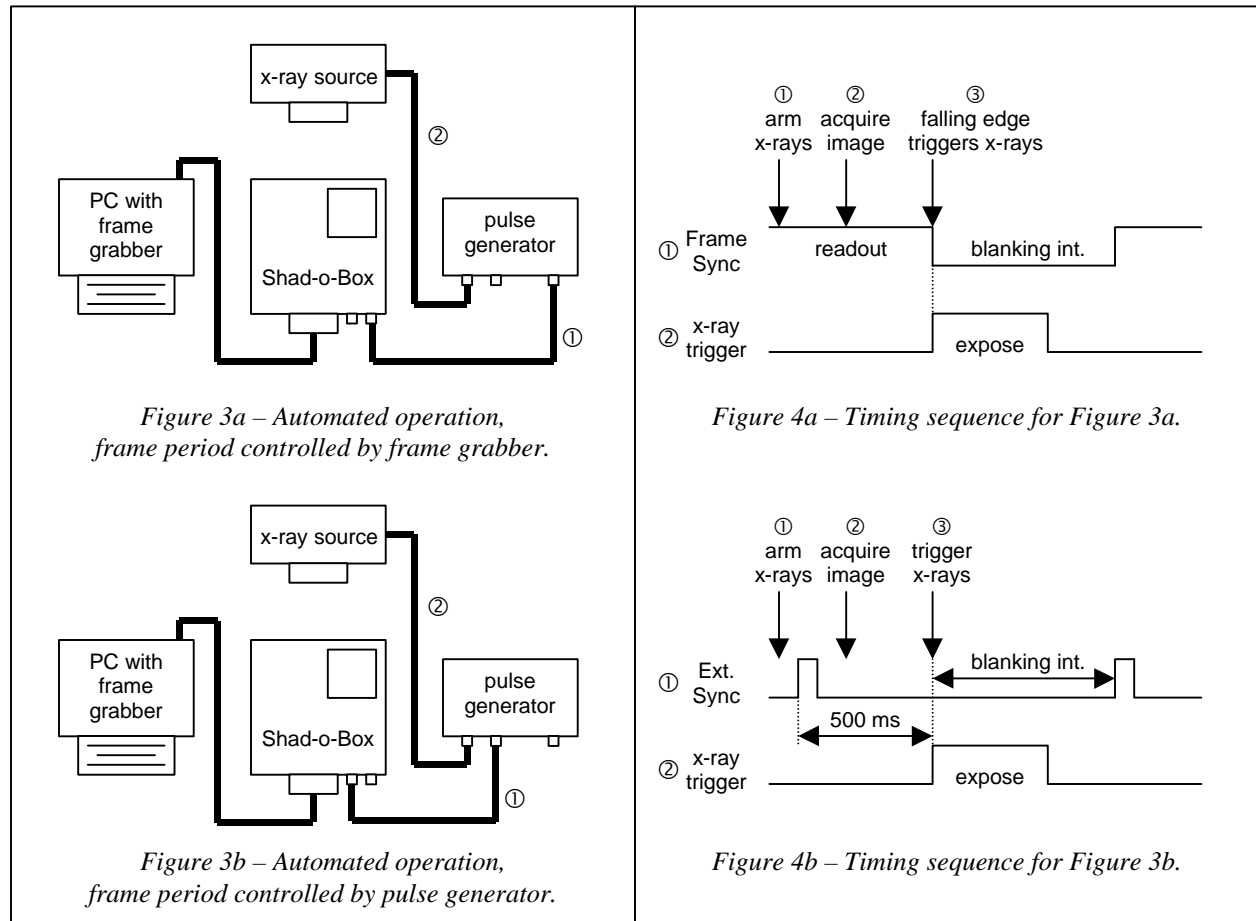

Acquiring a gain image is slightly more complicated. ShadoCam is programmed to acquire multiple flat-field images and average them in order to minimize the noise contribution from the gain correction algorithm. Unless the acquisition system is completely automated, this requires the operator to synchronize the x-ray source with the camera over an extended series of frames. It may be easier to just acquire a single, offset corrected image and use the "Make ... gain image" function in the *Gain Image* dialog box to designate it as the gain image.

In the case where frame averaging is required, there are some additional considerations. Your computer and frame grabber hardware may not be able to acquire consecutive images. To test your hardware capabilities, put ShadoCam into "Continuous Acquisition" mode and compare the frame counter in the status bar with the *Frame Sync* output on the Shad-o-Box camera. In particular, the DT3157 frame grabber tends to skip 2-3 frames between acquisitions when its exposure counter is used to control the frame period (Figure 2a). Since this delay is unpredictable, we recommend using a pulse generator to control the camera in this situation. With external control the DT3157 will typically acquire every other frame.

## RadEye Imager

The RadEye imager offers the same capabilities as the Shad-o-Box x-ray camera for controlling the timing of the image acquisition. In addition, the RadEye features some advanced imaging modes that have not been implemented in the Shad-o-Box.

### 1. Standard Modes

For a pulsed x-ray application the RadEye imager can be controlled using the same techniques as those we have described for the Shad-o-Box camera. The RadEye's *FRAME* output provides the same function as the *Frame Sync* output from the camera. (However, the RadEye imager can't directly drive an LED! All output signals from the RadEye imager should be buffered.) The *START* input on the RadEye imager corresponds to the *Ext. Sync* input to the Shad-o-Box. A pulse generator can be used to control the imaging system.

### 2. Half-Shutter Integration

The RadEye imager has an additional *RESET* input that enables the implementation of an electronic half-shutter integration mode. Half-shutter means that all the signal that is collected before the x-ray exposure starts can be flushed from the device at the beginning of the exposure (thus "opening" the shutter). The shutter has to be "closed" by turning off the x-rays and then reading out the device. Figure 5 shows the timing diagram for this mode.

The advantage of this mode is that it allows the imager timing to be controlled from the x-ray source. When the operator arms the x-rays, the *RESET* input is activated in order to clear all charge from the device. When the x-rays are triggered, the *RESET* input is released and the imager begins to integrate signal at the same instant at which the exposure begins. When the exposure is finished, a *START* pulse is sent to the imager in order to initiate the frame readout sequence. Since the *RESET* pulse can be very narrow ( $\geq 10 \mu\text{s}$ ), it is also possible to generate this pulse at the same time the x-rays are triggered without losing any significant amount of signal. Figure 5b shows this possibility. Since the RadEye imager resets each row of photodiodes as they are read out, the shutter has to be "closed" by terminating the x-ray exposure. Otherwise, each row would receive a different amount of signal.

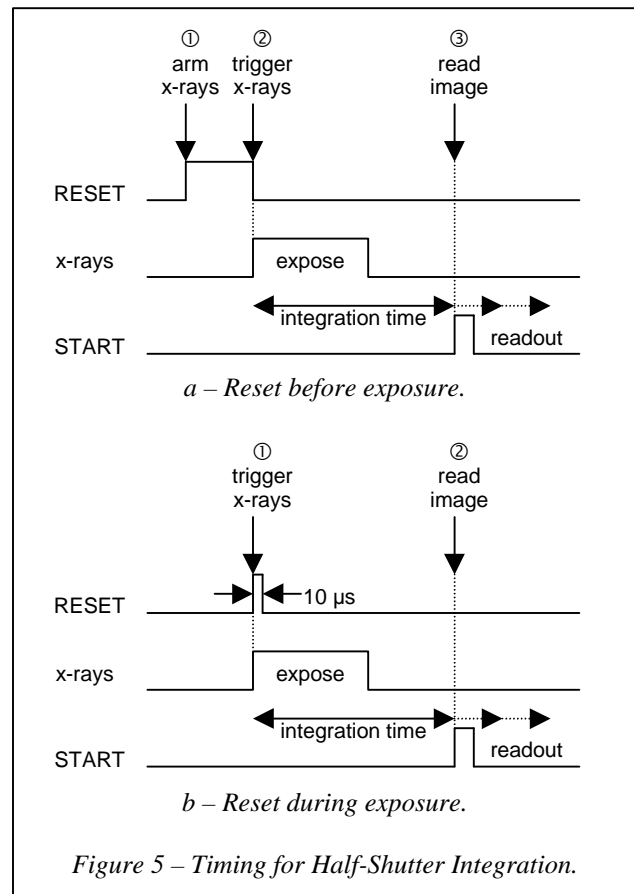

### 3. Non-Destructive Readout

The RadEye imager has a built-in non-destructive readout (NDR) mode that can be used to implement an auto-exposure function. When the *NDR* input is set high, the photodiodes are not being reset as part of the readout process. The imager can then be read out multiple times while it is accumulating signal. (Please refer to the RadEye datasheet for a complete description of the NDR mode.)

In an auto-exposure configuration, the rate at which the signal is accumulating determines how frequently the photodiodes need to be checked to see if enough signal is present. Fortunately, it is not necessary to read out an entire frame before making that determination. It is possible to just scan, for example, the first ten rows repeatedly, in which case a particular pixel could be monitored once every 2-5 milliseconds (depending on the clock frequency). Every time the imager receives a *START* pulse, the scan registers are reset and the readout process starts over. Since the pixels are not being reset, each successive partial frame will have just a little more signal than the one before it. When the acquisition software determines that there is enough signal, it terminates the exposure (by turning off the x-rays) and proceeds to read out the entire frame from the sensor. This scenario is shown in Figure 6a. Note that it is necessary to reset the photodiodes at the beginning of the exposure as in the half-shutter mode described previously.

A useful variation of the auto-exposure mode is shown in Figure 6b. When *NDR* is turned on, the built-in fixed pattern cancellation circuitry of the RadEye imager is disabled. It is therefore very important to perform an offset correction on the acquired image. The offset calibration image can be acquired at any time; however, it may be convenient to acquire it as part of the exposure sequence. This is accomplished by reading out a complete image after the *RESET* pulse occurs, before starting the exposure sequence described above. This first image contains all the fixed pattern offsets in the device, whereas the second image contains the fixed pattern plus the accumulated signal. The difference between the two images will yield just the signal by itself. An added benefit of this timing mode is that, since the pixels are not reset during the process, the pixel reset noise subtracts out as well. The reset noise typically limits the dark noise of the RadEye imager to ~150 electrons rms.

### Summary

We have described how the Shad-o-Box x-ray camera and the RadEye imager may be operated together with a pulsed x-ray source. Both camera and imager can be synchronized with the x-ray exposure, provided that either an external timing generator or a human operator are available to maintain the proper sequence of events. The RadEye imager also offers additional timing modes that allow even greater flexibility, such as a half-shutter mode, non-destructive readout and auto-exposure.

The system configurations and timing diagrams described in this application note are intended to be guidelines to aid in the design of a pulsed x-ray imaging system. Please consult the Shad-o-Box and RadEye datasheets for additional information on the control and data interface for these devices. The latest up-to-date information is available for download from our website at <http://www.rad-icon.com>.

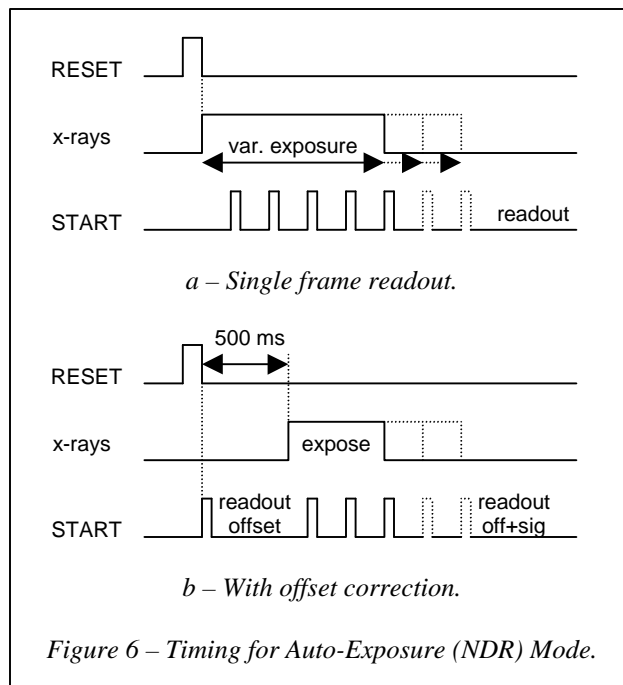

Figure 6 – Timing for Auto-Exposure (NDR) Mode.